

Motomate

Ready-to-use
brushless motor
with integrated controller



Intelligent motion



Motomate All the advantages of an all-in-one solution

Why choose Motomate?

- To reduce your overall costs thanks to its all-in-one functionality
- To reduce the time required to integrate programmable movements
- To reduce your maintenance operations
- To quarter the overall dimensions of your equipment
- To simplify your procurement processes
- To enhance your expertise

By integrating Motomate into your equipment you can benefit from all the advantages of an all-in-one function dedicated to programmable motion control. Motomate is a compact product combining Crouzet's expertise in automation and motorisation.

Results:

- Lower integration costs at design, assembly and installation stages
- Quick and easy debugging
- Industrially optimised control and motorisation functions guaranteed by Crouzet
- Long-term reduction in maintenance costs

Previously



100W asynchronous motor

Encoder

PLC

Variable speed drive

Now



Monobloc 80W Motomate

Logic controller: a true PLC complete with 4 inputs and 4 outputs and pre-programmed functions to simplify and reduce debugging operations. Analogue and digital inputs are also available.

Variable speed drive: a compact unit integrated in the motor control electronics, with functions optimised by design in comparison to more traditional solutions: variable speed, torque limiting, brake, resistance to locking, etc.

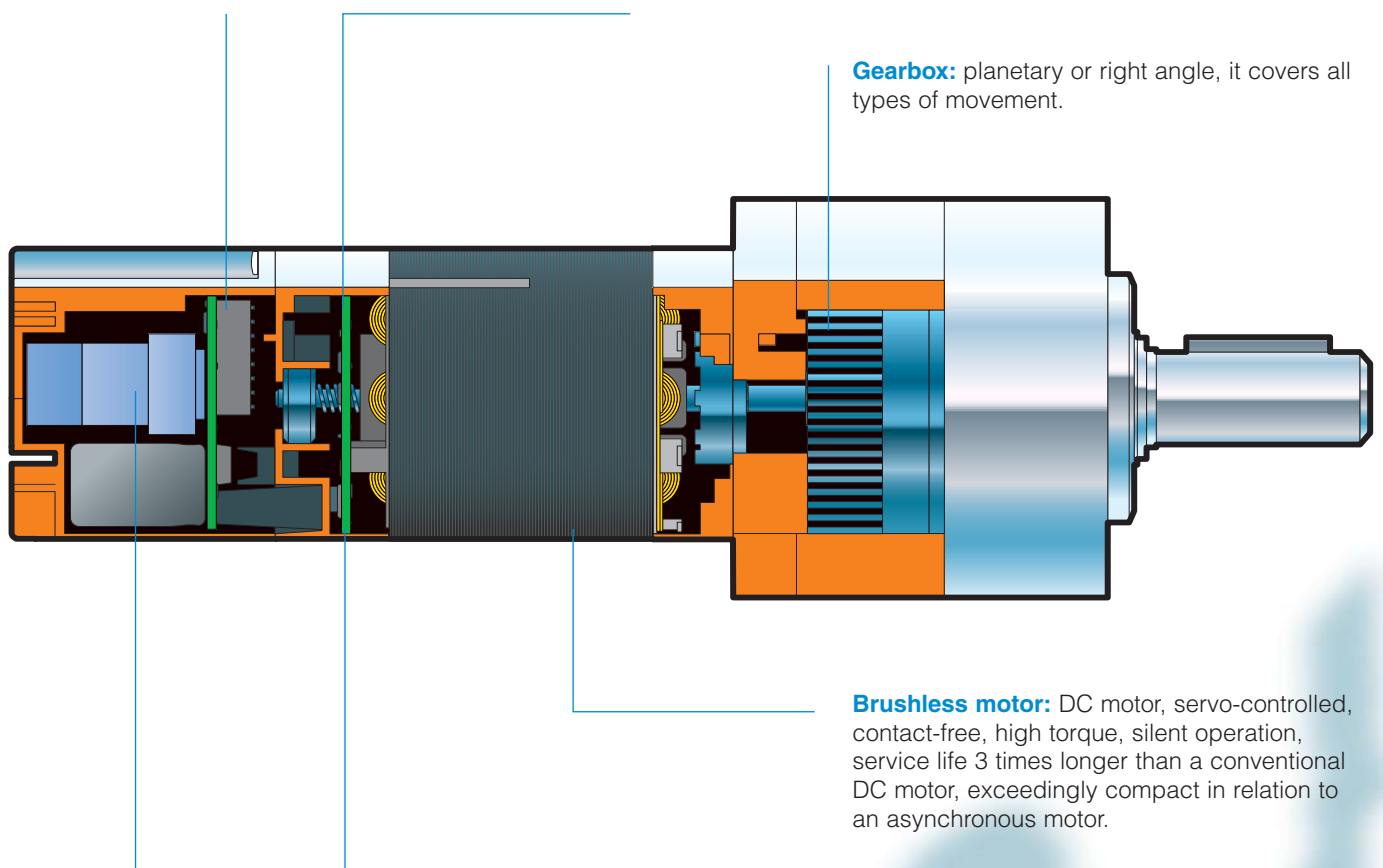

Motomate The dedicated solution for programmable



**A unique solution on the market:
Motomate is the only dedicated solution for
programmable motion control that is truly
industrially optimised.**

**With high capabilities in terms of overtorque/
braking and setting torque parameters, as well
as its strong automation control capability,
Motomate optimises the main programmable
movements: variable speed, motion and
position control.**

Motomate offers a simple and flexible solution for:

- Movements with acceleration and braking ramps
- Managing cyclical movements
- Self-teaching limit stops
- User-definable jam detection
- Interaction with control systems, sensors or actuators
- Time/Date-based programming, etc

Direct drive motor

With planetary gearbox

With right angle gearbox



**Make a difference
with Motomate**

Open/closing control for sliding lift doors:

“ ... Because Motomate is ready to integrate, simple to install and offers long-term reliability, it represents a real advance for us in terms of functional and economic performance... ”

Didier V. Lift installation, Project Manager

Intelligent conveying systems:

“ ... Motion is our business... With Motomate, we have chosen a highly reliable motorisation solution offering particularly flexible programming.

We certainly noticed the difference during a recent invitation to tender, thanks in particular to the reduction of indirect costs made possible by integrating Motomate... ”

Jim R. Packaging machinery, Chief Engineer

Adjusting machine limit stops:

“ ... We needed exact, repetitive and precise positioning of parts to be welded, and all with sufficient torque to move the parts.

With Motomate, we have found a highly reliable all-in-one function that can communicate with our information system and meets our industrial requirements... ”

Ralf H. Car manufacturer, New Works Manager

Robotics:

“ ... With Motomate's pre-programmed functions I have considerably reduced debugging times... ”

Lourdès G. Automation Engineer



Motomate The efficiency of true software features

4 functions pre-programmed specifically for Motomate...



Timer

Used to set a time delay between 2 movements



Movement

Used to reach a target position following speed ramps



Motor multiplexer

Used to group the On/Off, direction and speed outputs for several movement steps



High speed counter

Used to count motor pulses, indicate position and calculate speed

... plus a whole host of other functions

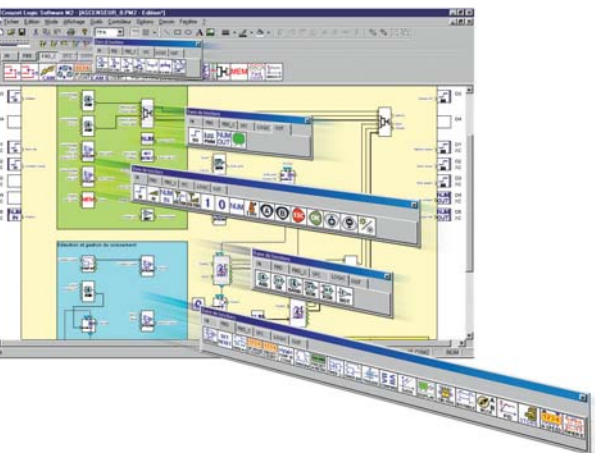

For electromechanics there's a range of pre-programmed functions:

- The functions dedicated to controlling movements and motors are pre-programmed and ready to use.
- There are logic, GRAFCET (SFC), counter, clock, fast counter functions to name but a few...
- The Motomate interface allows you to program intuitively using graphic blocks.

For automation specialists, Motomate's integrated PLC is a powerful tool:

- In addition to the selection of pre-programmed functions you can easily develop your specific programs using the PLCs integrated functions.
- You will have an open architecture that can communicate via fieldbus or modem to assist, for example, with remote maintenance.
- A highly flexible PLC. You will be able to enhance or even modify your programs very easily – just using a PC. Sensors or actuators can also be added to the I/O.



Integrated logic controller

Motomate From 30 to 80W, the range is extensive

Monobloc Motomate

For those who require a solution that is ready to integrate, compact, highly reliable, industrially optimised, with pre-programmed automation functions.

Benefiting in addition from Crouzet's commitment to high-performance.



Number of I/O	Type of output	Reduction ratio	Power	Max. speed	Available torque			
4I/4O MOTOMATE integrated logic controller	Direct drive motor	-	80 watts	3250 rpm	0.24 Nm	page 11		
		5		650 rpm	1.00 Nm			
	Right angle geared motor (30 to 500 rpm)	10		325 rpm	1.70 Nm			
		20		163 rpm	2.90 Nm			
		30		108 rpm	3.50 Nm			
		50		65 rpm	3.40 Nm			
		Planetary geared motor (3 to 500 rpm)		5	650 rpm		1.00 Nm	
				27	120 rpm		4.50 Nm	
				139	23 rpm		20.00 Nm	

Distributed Motomate

For those who require a high number of inputs and outputs.

You want to take advantage of the high performance offered by the Millenium II+ and the brushless motor for distributed functions and integrate them at your own convenience.



Up to 10I/50 Millenium II+ external logic controller	Direct drive motor (500 to 3000 rpm)	-	80 watts	3250 rpm	0.24 Nm	page 14	
			30 watts	2200 rpm	0.14 Nm	page 16	
	Right angle geared motor (30 to 500 rpm)	5		80 watts	650 rpm	1.00 Nm	page 18
				30 watts	440 rpm	0.60 Nm	page 19
		10		80 watts	325 rpm	1.70 Nm	page 18
				30 watts	220 rpm	1.00 Nm	page 19
		20		80 watts	163 rpm	2.90 Nm	page 18
				30 watts	110 rpm	1.70 Nm	page 19
	30		80 watts	108 rpm	3.50 Nm	page 18	
			30 watts	74 rpm	2.10 Nm	page 19	
	50		80 watts	65 rpm	3.40 Nm	page 18	
			30 watts	44 rpm	2.00 Nm	page 19	
	Planetary geared motor (3 to 500 rpm)	5		80 watts	650 rpm	1.00 Nm	page 20
				30 watts	316 rpm	0.80 Nm	page 22
		27		80 watts	120 rpm	4.50 Nm	page 20
				30 watts	48 rpm	5.00 Nm	page 22
		139		80 watts	23 rpm	20.00 Nm	page 20
				30 watts	7 rpm	30.00 Nm	page 22

Crouzet's other programmable movement solutions

Brushless motor

For those with their own speciality skills in the field of control electronics for developing specific functions.

You can therefore opt for a motorisation solution that integrates the power electronics.

Technology guide

Principle

1.1. Composition of the driving part:

Brushless motors comprise 3 main elements:

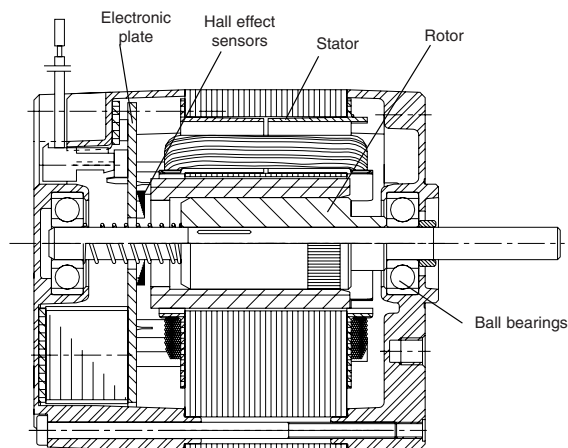

- A fixed part, the stator, which has three groups of coils, called the three phases of the motor. These coils operate as electromagnets and generate various orientations of magnetic field regularly distributed around the central shaft of the motor.

- A rotating part, the rotor, which has permanent magnets. Like the needle of a compass, these magnets permanently drive the rotor to try to align itself with the magnetic field of the stator. For optimum service life of the motor, the rotor is mounted on ball bearings.

- Three "Hall effect" magnetic sensors. These sensors provide information on the position of the rotor magnets at all times.

1.2. The integrated control electronics:

Crouzet brushless motors incorporate their control electronics as standard. The control electronics control the phases of the motor, regulate the speed and incorporate the encoder function.

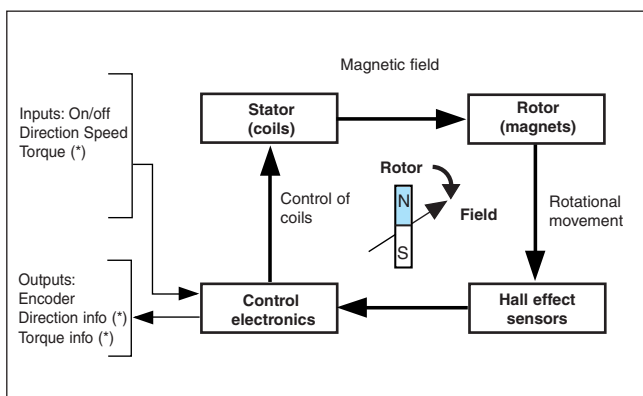

- The control electronics determine the position of the rotor using the Hall effect sensors. The electronics deduce from the sensors the orientation to give to the magnetic field of the stator. During rotation, they control the three coils to regularly adjust the orientation of the field to the position of the rotor, in order to drive it in the direction chosen by the user.

- By modulating the current in the coils, the electronics can accelerate or slow down the motor and thus regulate its speed. They can also orientate the magnetic field in order to brake the movement of the rotor to bring it to a standstill.

- By limiting the current in the coils, the electronics can also limit the torque of the motor, and activate the corresponding output

- The electronics also generate the outputs of the built-in encoder using the Hall effect sensors.

Speed regulation

2.1. What is 4-quadrant regulation?

The four zones of a torque/speed diagram are known as 'quadrants':

- A positive speed represents clockwise rotation, and a negative speed anti-clockwise

- A positive torque represents motor operation, and a negative torque brake operation.

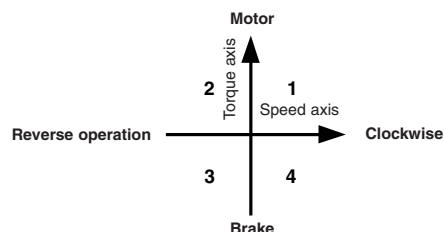

1-quadrant regulation operates in a single direction of rotation, with no possibility of braking. In the event of overspeed, the regulator cuts off the current until the motor is braked by the load

The principle is identical for 2-quadrant regulation, but in both directions of rotation. This operating mode is offered as an option on Crouzet brushless motors, when required by a specific application.

4-quadrant regulation also operates in both directions of rotation, but also allows braking. In the event of overspeed, the motor is involved in the braking and the system quickly loses speed.

All Crouzet brushless motors have 4-quadrant regulation as standard.

2.2. Braking:

Braking means absorbing the energy of the mechanical system. There are several different types of braking, depending on the use made of this absorbed energy:

Regenerative braking converts the energy of the system into electrical current, which will be directed to the motor power supply.

Apart from batteries, most commercially available power supplies do not accept this type of current feedback (they are known as 'non-reversible'). It is therefore necessary to ensure that the directed current can be consumed by another device, without which the power supply may be damaged. This braking mode is offered as an option on Crouzet brushless motors, but must be used with caution.

Crouzet brushless motors have braking 'without energy rejection' as standard. This means that on braking the kinetic energy of the system is converted into heat inside the motor itself, with no feedback to the power supply. This is the most suitable type of braking for most applications.

However, if there is prolonged braking, the heat that is generated may trip the thermal protection of the motor. For high inertia applications, or operation as a generator, PLEASE CONSULT CROUZET. Depending on the circumstances, our specialists will advise you to select either 2-quadrant regulation, or braking with energy rejection.

2.3. Control by PWM

PWM (Pulse Width Modulation) control is a method of indicating the speed setpoint to the motor. A PWM control motor should be chosen in the following cases:

- Control by CROUZET Millenium II logic controllers (see MOTOMATE information)
- Control by PLC with PWM outputs
- Control by digital control system

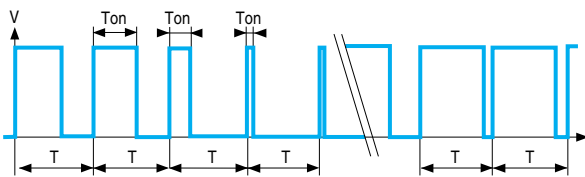

PWM control consists of pulse trains of fixed frequency (Period "T") but variable width ("Ton" period of the pulse). The speed setpoint depends on the Ton/T ratio. However it is independent of the voltage or frequency of the pulses, within the limits of the stated specifications.

Ton/T = 0%	Speed setpoint = 0
Ton/T = 100%	Speed setpoint = No-load speed of the motor
Ton/T = 50%	Speed setpoint = No-load speed of the motor/2

2.4. Control by 0-10V

0-10V voltage control is the other method of indicating the speed setpoint to the motor. A 0-10V input motor should be chosen in the following cases:

- Control by potentiometer
- Control by PLC with analogue converter outputs
- Control by analogue control system

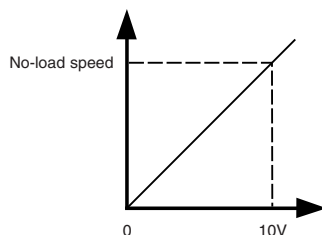

In this type of control, the speed setpoint depends on the voltage U at the speed setpoint input:

U = 0	Speed setpoint = 0
U = 10V	Speed setpoint = No-load speed of the motor
U = 5V	Speed setpoint = No-load speed of the motor/2

Torque limiting (*)

3.1. Operation

Torque limiting is used to deliberately check the motor at certain moments in the operation of a system:

- If there is a risk of encountering an end stop or jamming, to prevent damage to the system
- To maintain a force when the system is at an end stop
- To control the tension of an element located between two moving motor

3.2. Torque limiting input (*)

This input can be controlled in 0-10V and in PWM, whatever type of speed control is selected (Input impedance 16 k ohms. Minimum PWM voltage 12 volts.

Frequency range 150 Hz - 1 kHz

- When the input is at 0 or not connected, the motor delivers up to 140% of its nominal torque
- When the input is at maximum (100% PWM or 10V), the motor delivers around 30% of its nominal torque

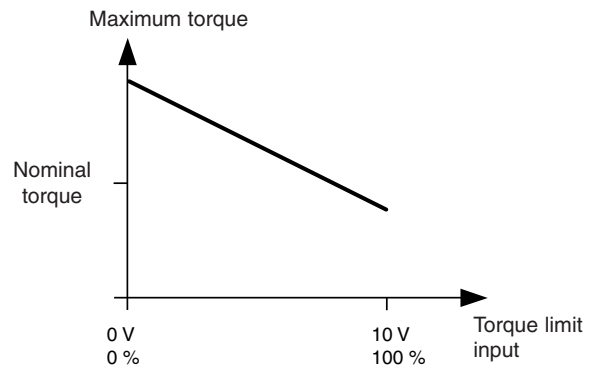

When the torque limit is reached, the motor does not follow its speed setpoint, but maintains a constant torque equal to this limit, as long as its speed remains below the setpoint.

3.3. Limit reached alert output (*)

This output is at logic state 1 when the torque limit is reached.

IMPORTANT: This output is PNP type. Consult the wiring diagrams and the precautions for use of this output in the motor specifications.

Built-in protection

4.1. 30 watt motors

If the motor locks when it is controlled, a protection system cuts off the power after a few seconds.

The motor can only restart when the On input changes to 0 then 1.

4.2. 80 watt motors

A temperature sensor incorporated in the motor switches the motor to safety mode when the temperature exceeds a value which may damage it. When the trigger temperature is reached, the power is cut off, which causes the motor to stop.

It can only restart when the temperature has fallen below the restart temperature and the On input has changed to 0 then 1.

Direction and on/off controls

Input logic table

On	Direction	Speed	Action
0	X	X	Braking and stop
1	X	0	Braking and stop
1	1	V	Clockwise direction at speed V
1	0	V	Anti-clockwise direction at speed V

On and Direction inputs:

- Input impedance: 60 Ω
- Logic state 0: < 2V
- Logic state 1: > 4V

Built-in encoder

The built-in encoder supplies fixed width pulses each time a Hall effect sensor switches. These pulses can be counted to ascertain the speed and position of the motor, or filtered to obtain an analogue signal proportional to the speed.

The additional direction of rotation (*) output is used to determine the direction of count of the pulses.

IMPORTANT: These outputs are NPN or PNP type depending on the version. Consult the wiring diagrams and the precautions for use of these outputs in the motor specifications.

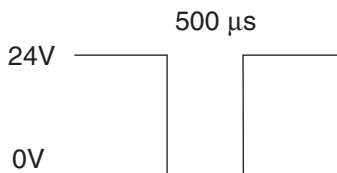

Safety

Crouzet BRUSHLESS DC motors are designed and manufactured to be integrated into appliances or machines which meet, for example, the specifications of the machine standard: EN 60335-1 (IEC 335-1, "Safety of household and similar electrical appliances").

The integration of Crouzet DC motors into appliances or machines should generally take account of the following motor characteristics:

- no earth connection
- "simple isolation" motors
- protection index: IP54
- insulation system class: B (120 °C)
- Vibration: EN 60068.2.6: 5G from 55 Hz to 500 Hz/0.35 mm peak to peak from 10 Hz to 55 Hz
- Shock: IEC 60068.2.27: 1/2 sine 50G for 11 ms

European low voltage directive 73/23/EEC of 19/02/73:

Crouzet DC motors and geared motors are outside the scope of this directive (LVD 73/23/EEC applies to voltages over 75 volts DC).

IMPORTANT

■ Product operation:

To ensure correct operation of Brushless actuators, it is advisable to take account of all the necessary installation and wiring precautions.

■ Product characteristics:

The stated nominal operating characteristics correspond to the voltage-torque-speed characteristics which permit continuous operation, at an ambient temperature of 40 °C. Above these operating conditions, only intermittent duty cycles will be possible: without exception, where extreme conditions prevail, all checks should be performed by the customer in the real-life context of the application to ensure safe operation.

-> **For operation in non-nominal conditions, please consult us**

■ Product usage:

If these products are being used in very specific operating conditions:

- food and beverage (eg: non-continuous, rectified)
- ambient atmosphere (extreme temperatures and vibrations, significant relative humidity, explosive or confined atmosphere, etc)

-> **other (use as load, sudden stalling, severe operating cycle, etc), please consult us**

EMC compatibility

On request, Crouzet will provide the EMC characteristics of the various types of product.

European directive 89/336/EEC of 03/05/89, "electromagnetic compatibility":

DC motors and geared motors which are components designed for professionals to be incorporated in more complex devices, and not for end users, are excluded from the scope of this directive.

However, conscious of the potential customer difficulties concerning problems connected with electromagnetic compatibility, Crouzet has designed its products to meet the requirements of the standards: for example EN 55011 Gr. 1 class B (medical) and also EN 55022, class B (data processing) in terms of emitted electromagnetic interference, in addition to standards connected with immunity:

IEC 1000- 4 -2/3/4/5/6/8

■ Wiring precautions

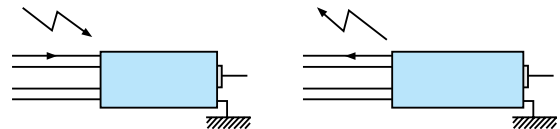

For EMC conformity:

- The motor should be connected to earth via its front flange.
- The length of the wires is 0.5 m max.

(* Note: Functions marked with an asterisk are only available on the 80 watt versions. If they are required on 30 watt motors, please consult Crouzet.

■ Electromagnetic compatibility:

Emission

- Conducted emissions: EN 55022/11G1 class B
- Radiated emissions: EN 55022/11G1 class B

Immunity

- Electrostatic discharges: EN 61000-4-2 Level 3
- Electromagnetic fields: EN 61000-4-3 level 3
- Pulse trains: EN 61000-4-4 level 3
- Shock waves: EN 61000-4-5 level 2
- Radio frequency: EN 61000-4-6 level 3
- Magnetic field: EN 61000-4-8 level 4
- Voltage dips: EN 61000-4-29

(* Note: Functions marked with an asterisk are only available on the 80 watt versions. If they are required on 30 watt motors, please consult Crouzet.

Motomate - Brushless motor with integrated logic controller

→ Motomate 80 watts

- Movement control for simple mechanisms
- All-in-one solution for quick integration
- Compact with high performance
- Intuitive programming with graphical function blocks
- Adapted for severe environments



Specifications

Type	Ratio	Max. speed (RPM)	Available torque (N.m)	Code
Motor direct drive	-	3 250	0.2	80 080 005
Right angle gearbox	5	650	1	80 081 001
	10	325	1.7	80 081 002
	20	163	2.9	80 081 003
	30	108	3.5	80 081 004
	50	65	3.4	80 081 006
Planetary gearboxes	5	650	1	80 089 704
	27	120	4.5	80 089 705
	139	23	20	80 089 706

Accessories

Designation	Code
Programming cable PC/Motomate - serial port	79 294 791
Programming cable PC/Motomate - USB	79 294 790
Programming software on CD ROM	79 294 792

General characteristics

General characteristics

Supply voltage (V)	24 (20 → 37)
Max. current (A)	6
Immunity from micro power cuts (ms)	1
Operating temperature (°C)	-20 → +40
Protection index	IP 54

Programming

Inputs / outputs	
Programming method	Function blocks / SFC
Program size	128
Program memory	Flash EEPROM
Program cycle time (ms)	10
Real-time clock	No

Logic inputs

Max. number	4 (I1 → I4)
Input impedance (kΩ)	> 10
Logic 1 voltage threshold (V)	> 15
Logic 0 voltage threshold (V)	< 5
Response time (ms)	10

High speed inputs

Max. number	2 (I1 → I2)
Max. frequency (KHz)	4

Analogue input

Max. number	2 (I3 → I4)
Measurement range	0-Vdc / 0-10 Vdc
Resolution	8 bits
Accuracy	± 5 %

Logic outputs / PWM

Max. number	4 (O1 → O4)
Type of output	PNP
Insulation	Non
Max. current (mA)	250
Leakage current (mA)	< 0.1
Response time (ms)	10
PWM frequency (KHz)	0.11 → 1.8
PWM precision at 120 Hz	5 %

Motor characteristics, see page 14.

Dimensions

Direct drive

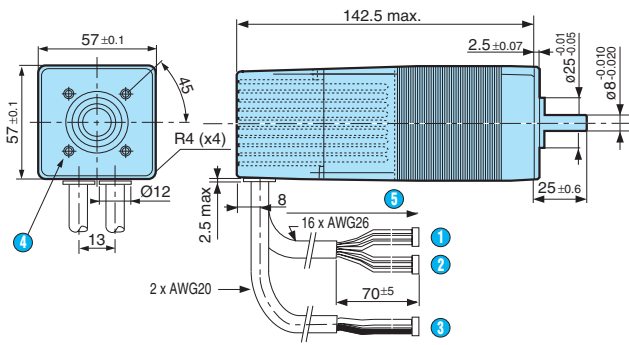

- 1 Connector 6 way Programming motomate
- 2 Connector 10 way Inputs/outputs motomate
- 3 Connector 2 way Power supply
- 4 4 holes M5 at 90° on $\varnothing 40$ depth 4.5 mini
- 5 Cable length : 500 ± 15 mm

Right angle gearbox

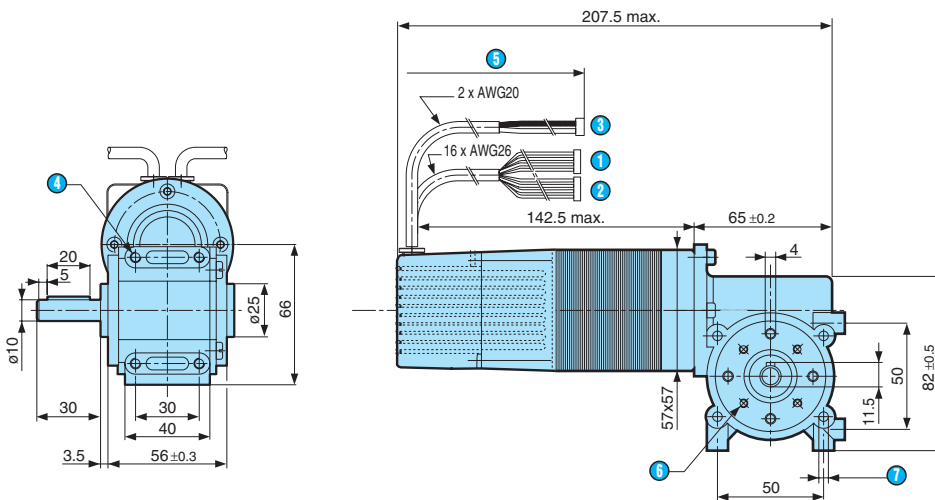

- 1 Connector 6 way Programming motomate
 - 2 Connector 10 way Inputs/outputs motomate
 - 3 Connector 2 way Power supply
 - 4 4 x M5 depth 8 mm
 - 5 Cable length 500 ± 5 mm
 - 6 4 x M4 on $\varnothing 36$ depth 8 mm
 - 7 4 x M5 depth 8 mm
- Radial load max. = 150 N
Axial load max. = 100 N

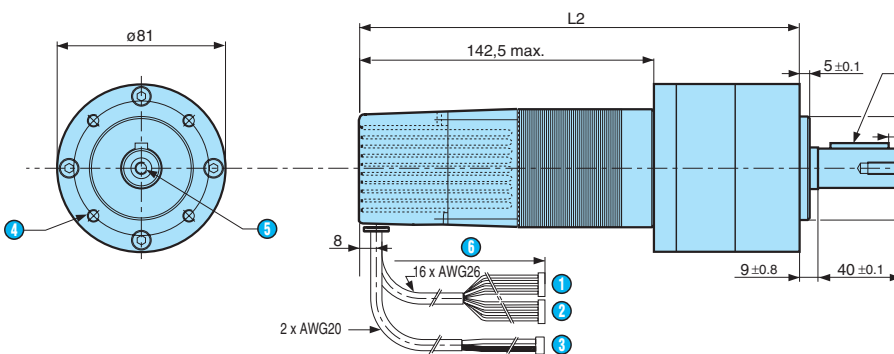

Planetary gearboxes



- 1 Connector 6 way Programming motomate
- 2 Connector 10 way Inputs/outputs motomate
- 3 Connector 2 way Power supply
- 4 4 holes M6 on $\varnothing 65$ depth 12 mm
- 5 Fixing hole M6 x 16
- 6 Cable length : 500 ± 15 mm
- 7 Key A6 x 6 x 28 according to DIN 6885

L2 Ratio 5 : 212.8 mm max.
L2 Ratio 27 : 234.7 mm max.
L2 Ratio 139 : 256.8 mm max.
Radial load max. = 200/300/500 N
Axial load max. = 80/120/200 N
(according to no. of stages)

Connections

Comment	Legend	Pin N°	Wire color	Motomate connector	Application connector
*a	+24V	1	Brown	1 power connector Molex 2-way (Ref. 51144-0200)	PCB side top view  Ref. 53520-0220
*a	GND	2	Black		
	IN1	1	Brown	1 I/O connector Molex 10-way 2.54 mm spacing (Ref. 90142-0010)	PCB side top view  Ref. 90130-1110
*b	OUT1	2	Blue		
	IN2	3	Orange		
*b	OUT2	4	Purple		
	IN3	5	Yellow		
*b	OUT3	6	Grey		
	IN4	7	Green		
*b	OUT4	8	White		
*a	GND	9	Black		
*a	+24V	10	Red		
*a	+5V	1	White-Red	1 programming connector Molex 6-way 2.54 mm spacing (Ref. 90142-0006)	PCB side top view  Ref. 90130-1106
*a	GND	2	White-Black		
	SCL	3	White-Yellow		
	SDA	4	White-Green		
	RX	5	White-Brown		
	TX	6	White-Orange		

Applications

Examples of input connections

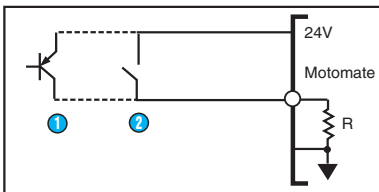

- 1 Sensor output PNP
- or
- 2 Contact

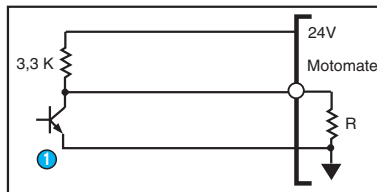

- 1 Sensor output NPN

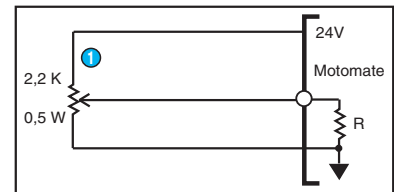

- 1 Potentiometer

Example of output connections

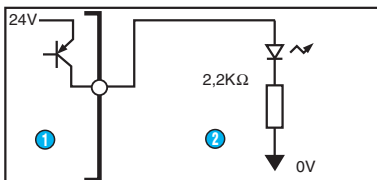

- 1 Motor
- 2 Load LED

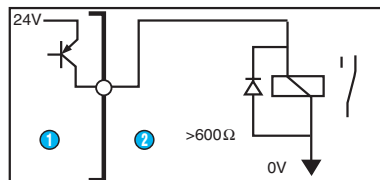

- 1 Motor
- 2 Load relay

Product adaptations

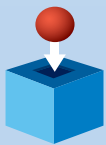

- Special output shaft
- Special supply voltage
- Special cable length
- Customised electronics
- Special connectors
- Special gear ratios
- Special pinion materials
- Special mounting plate

User information

- *a) Never reverse the polarity of the supply
- *b) Do not short-circuit the outputs O1 to O4 to earth
 - Do not use the motor as a generator
 - For more details on the geared motors, consult the brushless catalogue

Direct drive BRUSHLESS DC motors

→ 80 Watts

Ideal for movement and positioning applications

- Adjustable : 4 quadrant variable speed control
- Complete : Brake, 2 channel encoder and integrated CEM filter
- Compact : High efficiency and starting torque
- Open : Compatible with Crouzet Millenium II+ logic controller
- Flexible : 24 V supply allows battery operation



Specifications

	80 Watts PWM control	80 Watts 0-10 V control
Speed control	PWM	0-10 V
Part numbers	80 180 001	80 180 002
Supply voltage (V)	24 (18 → 37)	24 (18 → 37)
No-load characteristics		
Speed of rotation (rpm)	4 200	4 200
Absorbed current (A)	0.4	0.4
Nominal characteristics		
Speed (rpm)	3 250	3 250
Torque (mN.m)	240	240
Absorbed current (A)	4.8	4.8
Maximum characteristics		
Start torque (mN.m)	300	300
Starting current (A)	6.0	6.0
General characteristics		
Insulation class (conforming to IEC 85)	B (120°C)	B (120°C)
Casing temperature rise at 40°C ambient max. (°C)	20	20
Thermal time constant (min)	15	15
Inertia (g.cm ²)	105	105
Acoustic pressure at 50 cm (dBA)	50	50
Service life L10 (h)	20 000	20 000
0-10 V speed input characteristics		
Input impedance (kΩ)	-	440
Full scale speed (rpm)	-	4 200
PWM speed input characteristics		
Input impedance (kΩ)	19	-
Level 0 input voltage (V)	< 2.5	-
Level 1 input voltage (V)	> 11.5	-
Frequency range (Hz)	150 → 1000	-
Full scale speed (rpm)	4 200	-
Output characteristics		
Type of output	PNP	PNP
Max. current (mA)	50	50
Weight (g)	1 400	1 400

Product adaptations

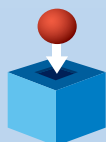

- 2 quadrant speed regulation,
- Motors with hall effect sensors only,
- Adaptations on electronics,
- Special cable lengths,
- Special connectors fitted to the cable.

Curves

Speed/torque

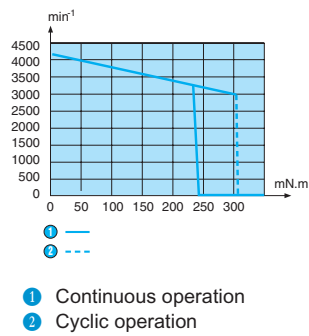

Current/torque

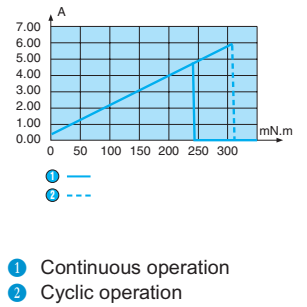

Dimensions

Short version 80 180 0

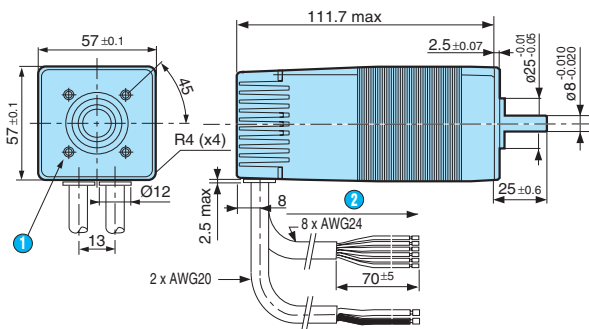

- ① 4 holes M5 x 0.86 H on Ø 40 depth 4.5 mm mini
- ② Cable length : 500 ± 15 mm

Connections

Marking on motor	Function	Wire colour	
*a	Power earth	Black (2nd harness)	1 power cable AWG20
*a	24 V power supply	Brown (2nd harness)	2 conductors UL2464
	Signal earth	Black	
	On/off input	Green	
	Direction input	Yellow	
	Speed setpoint	Orange	1 control cable AWG24
*b	12 points/rev encoder output	Brown	8 conductors UL2464
*b	Encoder direction output	Red	
	Torque limiting setpoint	Blue	
*b	Torque saturation output	Purple	

User information

- *a) Do not invert the polarities
- *b) Do not short-circuit the encoder output (PNP)
Do not use the motor as a generator

Direct drive BRUSHLESS DC motors

→ 30 Watts

Ideal for movement and positioning applications

- Adjustable : 4 quadrant variable speed control
- Complete : Brake, 2 channel encoder and integrated EMC filter
- Compact : High efficiency and starting torque
- Open : Compatible with Crouzet Millenium II+ logic controller
- Flexible : 24 V supply allows battery operation



Specifications

	30 Watts
Speed control	0-10 V and PWM
Part numbers	80 140 004
Supply voltage (V)	24 (18 → 28)
No-load characteristics	
Speed of rotation (rpm)	3 100
Absorbed current (A)	0.2
Nominal characteristics	
Speed (rpm)	2 200
Torque (mN.m)	140
Absorbed current (A)	1.9
Maximum characteristics	
Start torque (mN.m)	220
Starting current (A)	3.0
General characteristics	
Insulation class (conforming to IEC 85)	B (120°C)
Casing temperature rise at 40°C ambient max. (°C)	15
Thermal time constant (min)	15
Inertia (g.cm ²)	50
Weight (g)	800
Acoustic pressure at 50 cm (dBA)	40
Service life L10 (h)	20 000
0-10 V speed input characteristics	
Input impedance (kΩ)	10
Full scale speed (rpm)	3 100
PWM speed input characteristics	
Input impedance (kΩ)	10
Level 0 input voltage (V)	< 1.7
Level 1 input voltage (V)	> 3
Frequency range (Hz)	150 → 5 000
Full scale speed (rpm)	3 100
Output characteristics	
Type of output	NPN
Max. current (mA)	50

Product adaptations

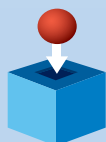

- 2 quadrant speed regulation,
- Motors with hall effect sensors only,
- Adaptations on electronics,
- Special cable lengths,
- Special connectors fitted to the cable.

Curves

Speed/torque

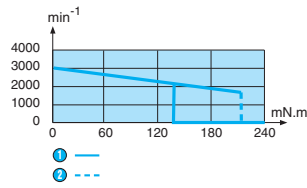

- ① Continuous operation
- ② Cyclic operation

Current/torque

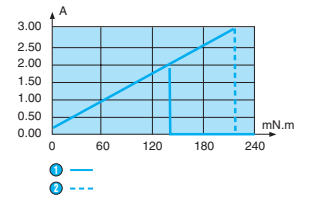

- ① Continuous operation
- ② Cyclic operation

Dimensions

Version IP 54

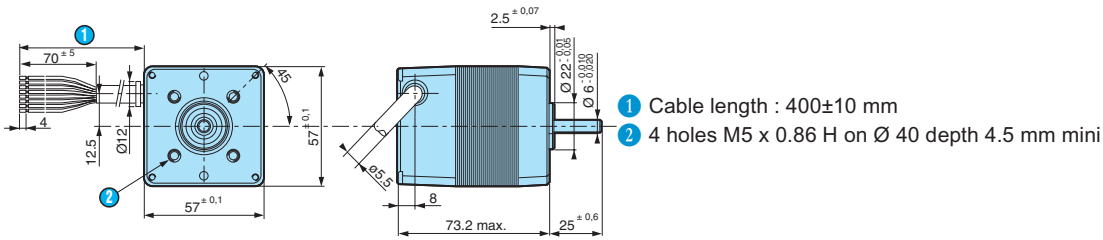

Connections

Marking on motor	Function	Wire colour
*a	Power earth	Black
*a	24 V power supply	Red
	Signal earth	Blue
	On/off input	Green
	Direction input	Yellow
	PWM speed setpoint	Orange
	0-10 V speed setpoint	Brown
*b	12 points/rev encoder output	Purple

1 power cable
AWG24
8 conductors
UL2464

User information

- *a) Do not invert the polarities
- *b) Do not short-circuit the encoder output (NPN)
Do not use the motor as a generator

BRUSHLESS DC geared motors

→ 80 Watts with right-angle gearbox

- Output perpendicular to motor,
- Ideal for low reduction ratios,
- Ideal for applications needing a compact motor,
- Silent operation,
- Mechanically irreversible with high ratios.



Specifications

Ratios (i)	Output speed (rpm)	Available torque (N.m)	80 Watts PWM control		80 Watts 0-10 V control	
5	650	1,0	80 181 001	80 181 010	80 181 010	80 181 010
10	325	1,7	80 181 002	80 181 011	80 181 011	80 181 011
20	163	2,9	80 181 003	80 181 012	80 181 012	80 181 012
30	108	3,5	80 181 004	80 181 013	80 181 013	80 181 013
50	65	3,4	80 181 006	80 181 015	80 181 015	80 181 015
General characteristics			80 180		80 180	
Motor			80 180	80 180	80 180	80 180
Speed control			PWM	PWM	0-10 V	0-10 V
Axial load dynamic (daN)			10	10	100	100
Radial load dynamic (daN)			15	15	150	150
Temperature rise at 50 % cycle (°C)			45	45	45	45
Weight (g)			1 920	1 920	1 920	1 920

Product adaptations

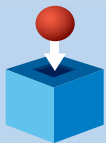

- 2 quadrant speed regulation,
- Motors with hall effect sensors only,
- Adaptations on electronics,
- Special cable lengths,
- Special connectors fitted to the cable.

Dimensions

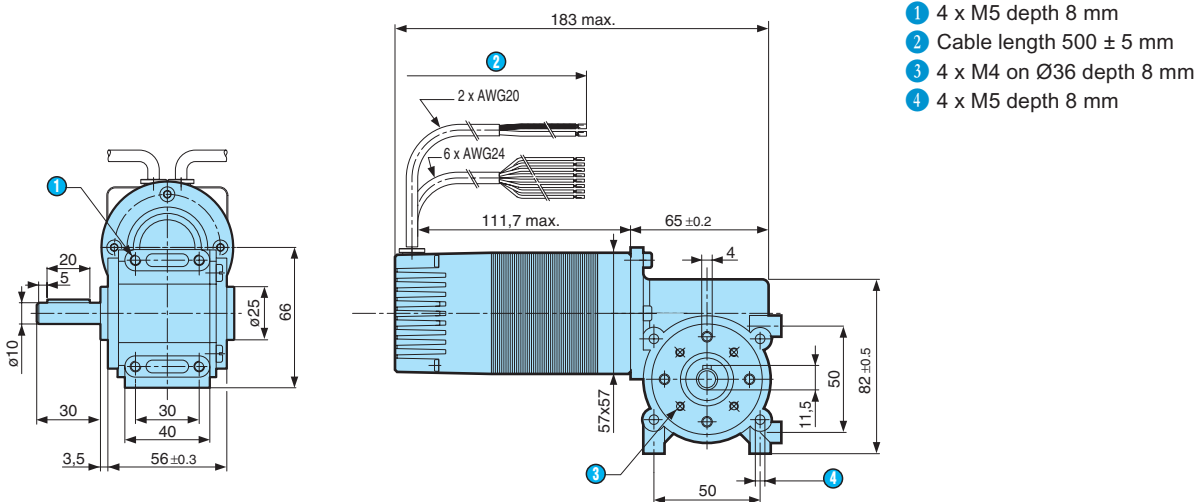

User information

Respect the limits and precautions of use written in the 80 W motor section.
 Continuous operation may cause overheating of the gearbox.
 This gearbox is recommended for applications where the on time does not exceed 50 % of the time, please consult us.

BRUSHLESS DC geared motors

→ 30 Watts with right-angle gearbox

- Output perpendicular to motor,
- Ideal for low reduction ratios,
- Ideal for applications needing a compact motor,
- Silent operation,
- Mechanically irreversible with high ratios.



Specifications

Ratios (i)	Output speed (rpm)	Available torque (N.m)	1 stage
5	440	0,6	80 141 001
10	220	1,0	80 141 002
20	110	1,7	80 141 003
30	74	2,1	80 141 004
50	44	2,0	80 141 006

General characteristics	
Motor	80 140
Speed control	0-10 V and PWM
Axial load dynamic (N)	100
Radial load dynamic (N)	150
Temperature rise at 50 % cycle (°C)	45
Weight (g)	1 480

Product adaptations

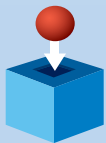

- 2 quadrant speed regulation,
- Motors with hall effect sensors only,
- Adaptations on electronics,
- Special cable lengths,
- Special connectors fitted to the cable.

Dimensions

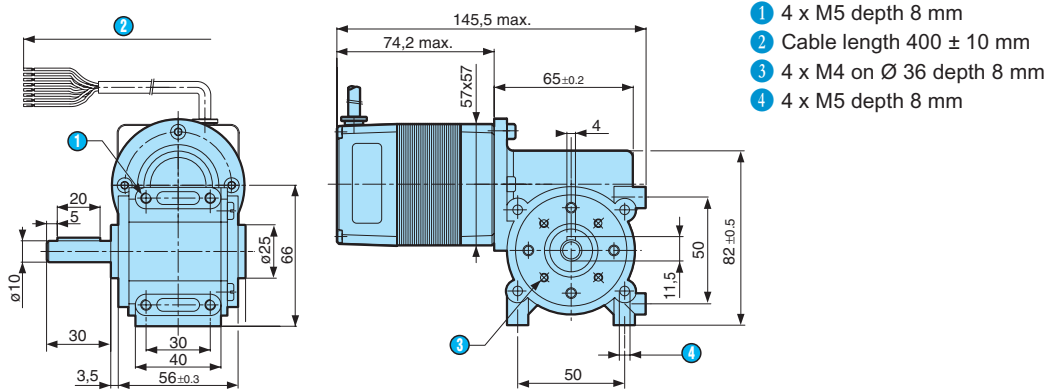

User information

Respect the limits and precautions of use written in the 30 W motor section.
 Continuous operation may cause overheating of the gearbox.
 This gearbox is recommended for applications where the on time does not exceed 50 % of the time, please consult us.

BRUSHLESS DC geared motors

→ 80 Watts with Ø 81 planetary gearboxes - PWM control

- Concentric output shaft
- Ideal for high reduction ratios
- Ideal for high torque applications
- High efficiency
- Reversible



Specifications

Ratios (i)	Output speed (rpm)	Available torque (N.m)	1 stage	2 stages	3 stages
5	650	1	80 189 701		
27	120	4,5		80 189 702	
139	23	20			80 189 703
General characteristics					
Motor			80 180	80 180	80 180
Speed control			PWM	PWM	PWM
Axial load dynamic (N)			80	120	200
Radial load dynamic (N)			200	300	500
Efficiency (%)			80	70	60
Casing temperature rise at 25°C			35	35	35
Weight (g)			3 200	3 900	4 600

Product adaptations

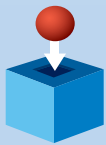

- 2 quadrant speed regulation,
- Motors with hall effect sensors only,
- Adaptations on electronics,
- Special cable lengths,
- Special connectors fitted to the cable.

Dimensions

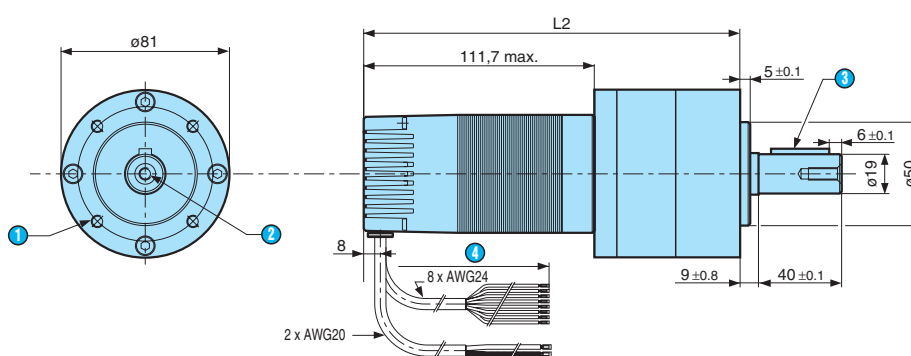

- 1 4 holes M6 x 12 on $\varnothing 65$
- 2 Fixing hole M6 x 16
- 3 Cable length 500 ± 15 mm
- 4 Key A6 x 6 x 28 according to DIN6885

L2 1 stage : 182 mm max.
 L2 2 stages : 203.9 mm max.
 L2 3 stages : 226 mm max.

User information

Respect the limits and precautions of use written in the 80W brushless motor section.

BRUSHLESS DC geared motors

→ 80 Watts with Ø 81 planetary gearbox - 0-10 V control

- Concentric output shaft,
- Ideal for high reduction ratios,
- Ideal for high torque applications,
- High efficiency,
- Reversible.



Specifications

Ratios (i)	Output speed (rpm)	Available torque (N.m)	1 stage	2 stages	3 stages
5	650	1	80 189 704		
27	120	4,5		80 189 705	
139	23	20			80 189 706
General characteristics					
Motor			80 180	80 180	80 180
Speed control			0-10 V	0-10 V	0-10 V
Axial load dynamic (N)			80	120	200
Radial load dynamic (N)			200	300	500
Efficiency (%)			80	70	60
Casing temperature rise at 25°C			35	35	35
Weight (g)			3 200	3 900	4 600

Product adaptations

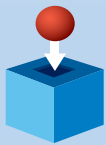

- 2 quadrant speed regulation,
- Motors with hall effect sensors only,
- Adaptations on electronics,
- Special cable lengths,
- Special connectors fitted to the cable.

Dimensions

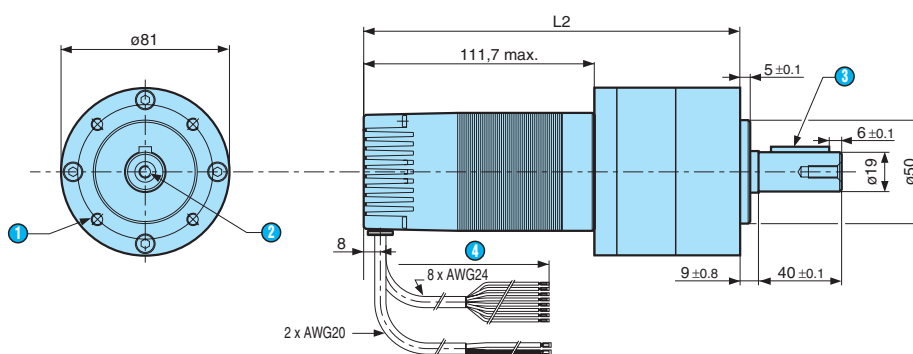

- 1 4 holes M6 x 12 x on $\phi 65$
- 2 Fixing hole M6 x 16
- 3 Cable length 500 ± 15 mm
- 4 Key A6 x 6 x 28 according to DIN6885

L2 1 stage : 182 mm max.
 L2 2 stages : 203.9 mm max.
 L2 3 stages : 226 mm max.

User information

Respect the limits and precautions of use written in the 80W brushless motor section.

BRUSHLESS DC geared motors

→ 30 Watts with Ø 62 planetary gearbox

- Concentric output shaft,
- Ideal for high reduction ratios,
- Ideal for high torque applications,
- High efficiency,
- Reversible.



Specifications

Ratios (i)	Output speed (rpm)	Available torque (N.m)	1 stage	2 stages	3 stages
7	316	0,8	80 149 604		
46	48	5		80 149 605	
308	7	30			80 149 606
General characteristics					
Motor			80 140	80 140	80 140
Speed control			0-10 V and PWM	0-10 V and PWM	0-10 V and PWM
Axial load dynamic (N)			50	70	120
Radial load dynamic (N)			240	360	520
Efficiency (%)			90	80	70
Casing temperature rise at 25°C			35	35	35
Weight (g)			1 600	2 000	2 400

Product adaptations

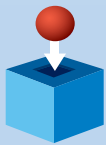

- 2 quadrant speed regulation,
- Motors with hall effect sensors only,
- Adaptations on electronics,
- Special cable lengths,
- Special connectors fitted to the cable.

Dimensions

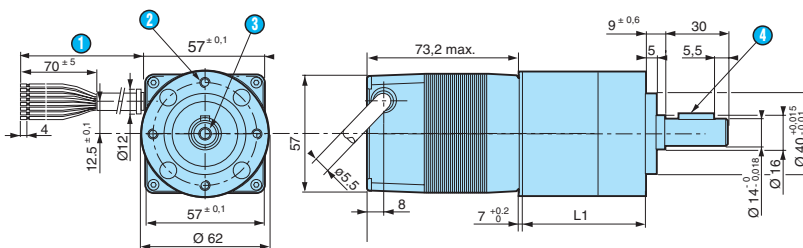

L1 1 stage : 43.7 mm max.
 L1 2 stages : 59.7 mm max.
 L1 3 stages : 75.2 mm max.

- 1 Cable length 400 ± 10 mm
- 2 4 holes M5 depth 10 at 90° on Ø52
- 3 Fixation hole M5 depth 12.5
- 4 Key A5 x 5 x 18

User information

Respect the limits and precautions of use written in the 30W brushless motor section

Motomate "The range is extensive"

An all-in-one solution
 The dedicated motion
 True software features
 The range is extensive
 Your questions

CATALOG

Horizontal motor:
 For those who require a solution that is ready to integrate, compact, light weight, industrial, or equipped with pre-programmed functions. Benefiting in addition from Crouzet's commitment to high performance.

Distributed motor:
 For those who require a high number of inputs and outputs. The need to take advantage of the high performance of a true PLC.

Number of I/O	Type of output	Reduction ratio	Power	Max. speed	Available torque
-	Direct drive motor	-	200 W	3200 rpm	0.24 Nm
8	Right angle geared motor (10 to 500 rpm)	10	80 W	620 rpm	1.00 Nm
10	Right angle geared motor (10 to 500 rpm)	20	160 W	310 rpm	1.70 Nm
30	Right angle geared motor (10 to 500 rpm)	30	80 W	100 rpm	3.20 Nm
50	Right angle geared motor (10 to 500 rpm)	50	40 W	40 rpm	5.40 Nm
8	Planetary geared motor (3 to 500 rpm)	3	450 W	1.00 rpm	1.00 Nm
17	Planetary geared motor (3 to 500 rpm)	17	120 W	120 rpm	4.50 Nm
119	Planetary geared motor (3 to 500 rpm)	119	22 W	22 rpm	20.00 Nm
-	Direct drive motor (500 to 3000 rpm)	-	80 W	3200 rpm	0.24 Nm
-	Direct drive motor (500 to 3000 rpm)	-	100 W	2500 rpm	0.34 Nm
9	Right angle geared motor (30 to 500 rpm)	9	80 W	400 rpm	0.63 Nm
10	Right angle geared motor (30 to 500 rpm)	10	100 W	300 rpm	1.70 Nm
30	Right angle geared motor (30 to 500 rpm)	30	80 W	100 rpm	3.20 Nm
50	Right angle geared motor (30 to 500 rpm)	50	40 W	40 rpm	5.40 Nm
8	Planetary geared motor (3 to 500 rpm)	3	450 W	1.00 rpm	1.00 Nm
17	Planetary geared motor (3 to 500 rpm)	17	120 W	120 rpm	4.50 Nm
46	Planetary geared motor (3 to 500 rpm)	46	30 W	40 rpm	5.00 Nm
119	Planetary geared motor (3 to 500 rpm)	119	20 W	22 rpm	20.00 Nm
300	Planetary geared motor (3 to 500 rpm)	300	10 W	7 rpm	50.00 Nm

Motomate "An all-in-one solution"

An all-in-one solution
 The dedicated solution
 True software features
 The range is extensive
 Your questions

CATALOG

Why choose Motomate 2 ?
 • To reduce your overall costs thanks to its all-in-one functionality
 • To reduce the time required to integrate programmable movements
 • To reduce your maintenance operations
 • To quarter the overall dimensions of your equipment
 • To simplify your procurement processes
 • To enhance your expertise

By integrating Motomate into your equipment you can benefit from all the advantages of an all-in-one function dedicated to programmable motion control. Motomate is a compact product combining Crouzet's expertise in automation and motorisation.

Results:
 • Lower integration costs at design, assembly and installation stages.
 • Quick and easy debugging.
 • Industrially optimised control and motorisation functions guaranteed by Crouzet.
 • Long-term reduction in maintenance costs.

Ready-to-use brushless motor with integrated controller

- EMC filter:** This neutralises electronic interference both inside and outside the motor.
- Logic controller:** A true PLC complete with 4 inputs and 4 outputs and pre-programmed functions to simplify and reduce debugging operations. Analogue and digital inputs are also available.
- Variable speed drive:** A compact unit integrated in the motor control electronics, with functions optimised by design in comparison to more traditional solutions: Variable speed, torque limiting, brake, resistance to locking, etc.
- Encoder:** 2-channel, provides all necessary information regarding motor position and direction of rotation.
- Brushless motor:** DC motor, servo-controlled, contact-free, high torque; silent operation, service life 3 times longer than a conventional DC motor; exceedingly compact in relation to an asynchronous motor.
- Gearbox:** Planetary or right angle, it covers all types of movement.

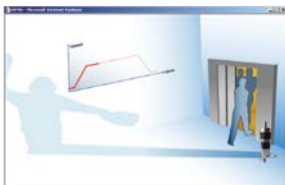



Crouzet around the world

AUSTRIA

Crouzet GmbH
Zweigniederlassung Österreich
Spengergasse 1/3
A-1050 WIEN
Tel. : +43(0) 1/36 85 471
Fax : +43(0) 1/36 85 472
E-mail : com-at@crouzet.com
www.crouzet.at

Customer services

Tel. : +49(0) 21 03/980 171
Fax : +49(0)21 03/980 222
E-mail : info-direkt@crouzet.com

BELGIUM

Crouzet NV/SA
Koning Albert I Laan 40
1780 Wemmel
Tel. : +32 (0) 2 462 07 30
Fax : +32 (0) 2 461 00 23
E-mail : com-be@crouzet.com
www.crouzet.be



Crouzet Direct

Tel. : +33 825 333 350 (FR)
Tel. : +33 475 802 104 (NL)
Fax : +33 475 802 120
E-mail : infocom@crouzet.com

BRAZIL

Crouzet do Brasil Ltda
Rua Gal.Furtado Nascimento,
740 - sl. 77 Alto de Pinheiros
CEP: 05465-070 São Paulo
SP - Brasil
Tel. : (11) 3026 9008
Fax : (11) 3026 9009
E-mail : crz-infobrasil@crouzet.com
www.crouzet.com



Crouzet Direct

Tel. : +33 475 802 102
Fax : +33 475 802 120
E-mail : infocom@crouzet.com

CHINA

Crouzet Asia
Dynasty Business Center,
310-3F
457 Wu Lu Mu Qi (N) Road
SHANGHAI
Tel. : +(86-21) 62 49 09 10
Fax : +(86-21) 62 49 07 01
E-mail : com-cn@crouzet.com
www.crouzet.com



Crouzet Direct

Tel. : +33 475 802 102
Fax : +33 475 802 120
E-mail : infocom@crouzet.com

FRANCE

Crouzet Automatismes SAS
Ventes France
2 rue du docteur Abel
BP 59 - 26 902 Valence
cedex 9
Tel. : 04 75 44 88 44
Fax N° Azur : 0 810 61 01 02
E-mail : com-fr@crouzet.com
www.crouzet.fr



Crouzet Direct

N° Indigo 0 825 33 33 50
Fax : 04 75 80 21 20
E-mail : infocom@crouzet.com

GERMANY

Crouzet GmbH
Otto-Hahn Str.3
D-40721 HILDEN
Postfach 203
D-40702 HILDEN
Tel. : +49(0) 21 03/980-0
Fax : +49(0)21 03/980-200
E-mail : com-de@crouzet.com
www.crouzet.de

Customer services

Tel. : +49(0) 21 03/980 151/171
Fax : +49(0) 21 03/980 222
E-mail : info-direkt@crouzet.com

INDIA

Crouzet India
India liaison office
Unit No. 3-D,
"SPL ENDERLY" III Floor,
26, Cubbon road
BANGALORE 560 001
Tel. : +91 80 30611862
Fax : +91 80 51238066
E-mail : crz_bangalore@crouzet.com
www.crouzet.com



Crouzet Direct

Tel. : +33 475 802 102
Fax : +33 475 802 120
E-mail : infocom@crouzet.com

ITALY

Crouzet Componenti s.r.l.
Via Brembo, 23
20139 Milano
Tel. : +39 02 57 306 611
Fax : +39 02 57 306 723
E-mail : com-it@crouzet.com

MEXICO

Crouzet Mexicana SA
Aguiles Serdan n° 416
San Felipe Hueyotlipan C.P.
72030 - Puebla Mexico
Tel. : +52 22 24 20 29/ 30
Fax : +52 22 24 21 47
E-mail : com-mx@crouzet.com
www.crouzet.com



Crouzet Direct

Tel. : +33 475 802 103
Fax : +33 475 802 120
E-mail : infocom@crouzet.com
www.crouzet.com

SPAIN

Crouzet España
C/ Aragón 224
08011 Barcelona
Tel. : +34 93 484 39 70
Fax : +34 93 484 39 73
E-mail : es-consultas@crouzet.es
www.crouzet.es



Crouzet Direct

Tel. : +33 475 802 103
Fax : +33 475 802 120
E-mail : infocom@crouzet.com

SWEDEN

Crouzet AB
Malmgårdsvägen 63
Box 11183 - SE. 100 61
Stockholm
Tel. : +46-8 556 02 200
Fax : +46-8 556 02 229
E-mail : crouzet@crouzet.se
www.crouzet.se

Customer services

Tel. : +46-8-556 02 210
Fax : +46-8 556 02 229
E-mail : order@crouzet.se

SWITZERLAND

Crouzet AG
Gewerbepark - Postfach 56
CH-5506 MÄGENWIL
Tel. : +41(0) 62/887 30 30
Fax : +41(0) 62/887 30 40
E-mail : com-ch@crouzet.com
www.crouzet.ch

Customer services

Tel. : +41(0) 62/887 30 30
Fax : +41(0) 62/887 30 40
E-mail : info-direkt@crouzet.com

THE NETHERLANDS

Crouzet BV
Industrieweg 17
2382 NR Zoeterwoude
Tel. : +31 (0)71-581 20 30
Fax : +31 (0)71-541 35 74
E-mail : com-nl@crouzet.com
www.crouzet.nl



Crouzet Direct

Tel. : +33 475 802 104
Fax : +33 475 802 120
E-mail : infocom@crouzet.com

UNITED KINGDOM

Crouzet Ltd
Intec 3 - Wade Road
Basingstoke - Hampshire
RG24 8NE
Tel. : +44 (0)1256 318 900
Fax : +44 (0)1256 318 901
E-mail : info@crouzet.co.uk
www.crouzet.co.uk

USA

Crouzet Corporation
204 airline drive, suite 300
Coppell Texas 75019
Tel. : +1 972 471-2555
Fax : +1 972 471-2560
E-mail : com-us@crouzet.com
www.crouzet-usa.com



Crouzet Direct

Tel. : +33 475 802 102
Fax : +33 475 802 120
E-mail : infocom@crouzet.com

OTHER COUNTRIES

Crouzet Automatismes SAS
Division Ventes Internationales
2 rue du docteur Abel - BP 59
26902 Valence cedex 9 - Fr
Tel. : +33 475 448 936
Fax : +33 475 448 126
E-mail : com-dvi@crouzet.com
www.crouzet.com



Crouzet Direct

Tel. : +33 475 802 102
Fax : +33 475 802 120
E-mail : infocom@crouzet.com

Warning:

The product information contained in this catalogue is given purely as information and does not constitute a representation, warranty or any form of contractual commitment. CROUZET Automatismes and its subsidiaries reserve the right to modify their products without notice. It is imperative that we should be consulted over any particular use or application of our products and it is the responsibility of the buyer to establish, particularly through all the appropriate tests, that the product is suitable for the use or application. Under no circumstances will our warranty apply, nor shall we be held responsible for any application (such as any modification, addition, deletion, use in conjunction with other electrical or electronic components, circuits or assemblies, or any other unsuitable material or substance) which has not been expressly agreed by us prior to the sale of our products.

Distributed by :