

CIMR-F7Z

Varispeed F7

Frequency inverter for full flux vector control

- Current Vector Control with or without PG
- Torque Control
- PID Control
- Standard LCD operator
- Fieldbus options: DeviceNet, Profibus, CANOpen
- Stand still Autotuning
- Powerful application oriented functionality
- High slip braking
- PLC Option card
- Easy maintenance
- Energy saving function
- Standard RS485 communications - Modbus
- CE, UL, and cUL marking
- Customized application firmware

Ratings

- 200V Class three-phase 0.4 to 110KW
- 400V Class three-phase 0.4 to 300 KW



System Configuration

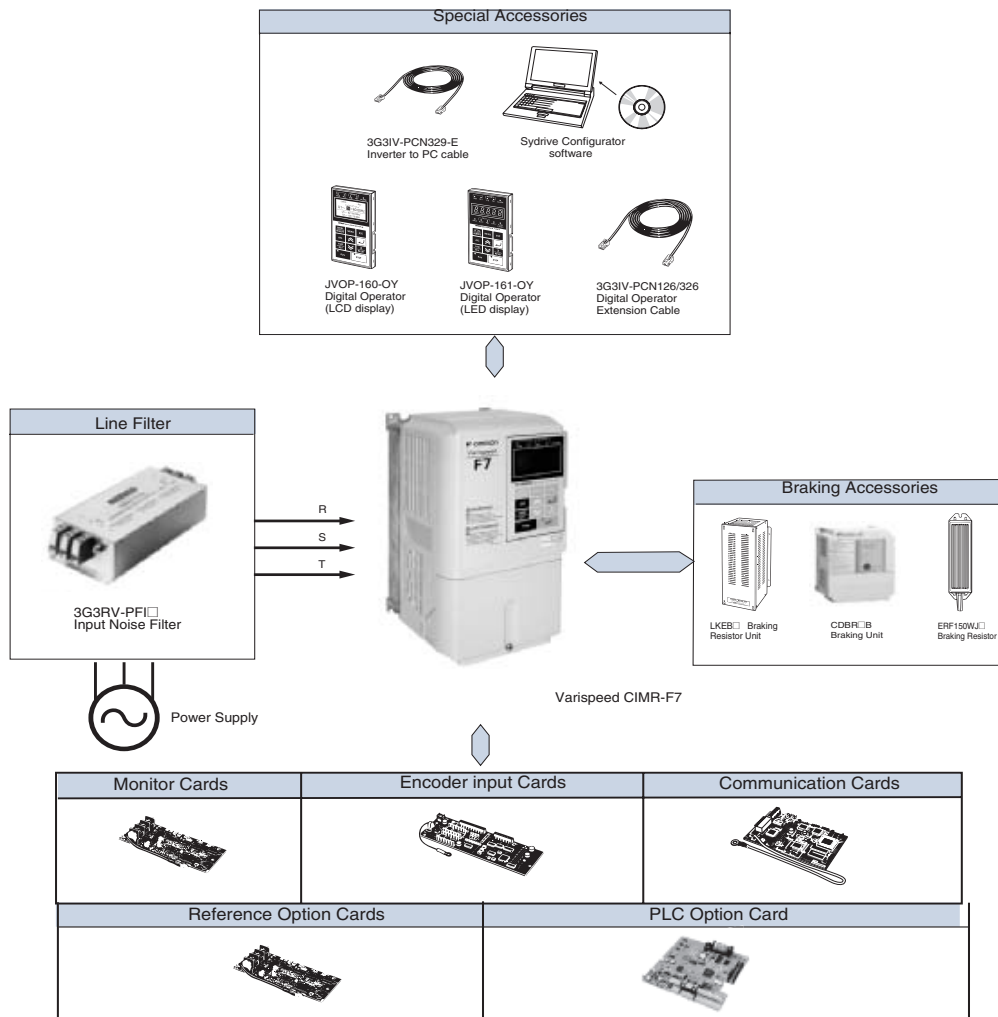

Specifications

Type Designation

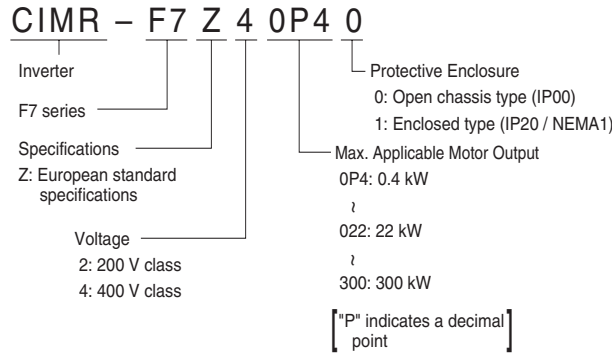

200 V Class

| Model CIMR-F7Zo | | 20P4 | 20P7 | 21P5 | 22P2 | 23P7 | 25P5 | 27P5 | 2011 | 2015 | 2018 | 2022 | 2030 | 2037 | 2045 | 2055 | 2075 | 2090 | 2110 |
|--|-----------------------------------|---|------|------|------|------|------|------|------|------|------|------------------------|------|------|------|------|------|------|------------------|
| Max. applicable motor output ¹ kW | | 0.55 | 0.75 | 1.5 | 2.2 | 3.7 | 5.5 | 7.5 | 11 | 15 | 18.5 | 22 | 30 | 37 | 45 | 55 | 75 | 90 | 110 |
| Output characteristics | Inverter Capacity kVA | 1.2 | 1.6 | 2.7 | 3.7 | 5.7 | 8.8 | 12 | 17 | 22 | 27 | 32 | 44 | 55 | 69 | 82 | 110 | 130 | 160 |
| | Rated Current A | 3.2 | 4.1 | 7.0 | 9.6 | 15 | 23 | 31 | 45 | 58 | 71 | 85 | 115 | 145 | 180 | 215 | 283 | 346 | 415 ² |
| | Max. Voltage | 3-phase, 200/208/220/230/240 V (Proportional to input voltage) | | | | | | | | | | | | | | | | | |
| | Max. output Frequency | Heavy Duty (low carrier, constant torque applications): 150 Hz max Normal Duty 1 or 2 (High/reduced carrier, variable torque applications): 400 Hz max | | | | | | | | | | | | | | | | | |
| Power Supply | Rated Input Voltage and Frequency | 3-phase 200/208/220/230/240 V, 50/60 Hz ³ | | | | | | | | | | | | | | | | | |
| | Allowable Voltage Fluctuation | +10%, -15% | | | | | | | | | | | | | | | | | |
| | Allowable Frequency Fluctuation | ±5% | | | | | | | | | | | | | | | | | |
| Harmonic Wave Prevention | DC Reactor | Option | | | | | | | | | | Provided | | | | | | | |
| | 12-Pulse Input | Not available | | | | | | | | | | Available ⁴ | | | | | | | |

- Our standard 4-pole motors are used for max. applicable motor output. Choose the inverter model whose rated current is allowable within the motor rated current range.
- 322 A in case of Heavy duty mode
- When using the inverter of 200 V class 37 kW or more with a cooling fan of three-phase 230 V 50 Hz or 240 V 50/60 Hz power supply, a transformer for the cooling fan is required.
- A 3-wired transformer is required at 12-pulse input.

400 V Class

| Model CIMR-F7Zo | | 40P4 | 40P7 | 41P5 | 42P2 | 43P7 | 44P0 | 45P5 | 47P5 | 4011 | 4015 | 4018 | 4022 | 4030 | 4037 | 4045 | 4055 | 4075 | 4090 | 4110 | 4132 | 4160 | 4185 | 4220 | 4300 |
|--|-----------------------------------|---|------|------|------|------|------|------|------|------|------|------------------------|------|------|------|------|------|------|------|------|------|------|------|------------------|------------------|
| Max. applicable motor output ¹ kW | | 0.55 | 0.75 | 1.5 | 2.2 | 3.7 | 4.0 | 5.5 | 7.5 | 11 | 15 | 18.5 | 22 | 30 | 37 | 45 | 55 | 75 | 90 | 110 | 132 | 160 | 185 | 220 | 300 |
| Output characteristics | Inverter Capacity kVA | 1.4 | 1.6 | 2.8 | 4.0 | 5.8 | 6.6 | 9.5 | 13 | 18 | 24 | 30 | 34 | 46 | 57 | 69 | 85 | 110 | 140 | 160 | 200 | 230 | 280 | 390 | 510 |
| | Rated Current A | 1.8 | 2.1 | 3.7 | 5.3 | 7.6 | 8.7 | 12.5 | 17 | 24 | 31 | 39 | 45 | 60 | 75 | 91 | 112 | 150 | 180 | 216 | 260 | 304 | 370 | 506 ² | 675 ³ |
| | Max. Voltage | 3-phase, 380/400/415/440/460/480 V (Proportional to input voltage) | | | | | | | | | | | | | | | | | | | | | | | |
| | Max. output Frequency | Heavy Duty (low carrier, constant torque applications): 150 Hz max Normal Duty 1 or 2 (High/reduced carrier, variable torque applications): 400 Hz max | | | | | | | | | | | | | | | | | | | | | | | |
| Power Supply | Rated Input Voltage and Frequency | 3-phase 380/400/415/440/460/480 V, 50/60 Hz | | | | | | | | | | | | | | | | | | | | | | | |
| | Allowable Voltage Fluctuation | +10%, -15% | | | | | | | | | | | | | | | | | | | | | | | |
| | Allowable Frequency Fluctuation | ±5% | | | | | | | | | | | | | | | | | | | | | | | |
| Harmonic Wave Prevention | DC Reactor | Option | | | | | | | | | | Provided | | | | | | | | | | | | | |
| | 12-Pulse Input | Not available | | | | | | | | | | Available ⁴ | | | | | | | | | | | | | |

- Our standard 4-pole motors are used for max. applicable motor output. Choose the inverter model whose rated current is allowable within the motor rated current range.
- 405 A in case of Heavy duty mode
- 540 A in case of Heavy duty mode
- A 3-wired transformer is required at 12-pulse input.

Enclosures

| 200V Class | Model CIMR-F7Z□ | 20P4 | 20P7 | 21P5 | 22P2 | 23P7 | 25P5 | 27P5 | 2011 | 2015 | 2018 | 2022 | 2030 | 2037 | 2045 | 2055 | 2075 | 2090 | 2110 | | | | | |
|------------------------------|--|-----------------------|------|------|------|------|------|------|------|------|------|-----------------------|----------------------|------|------|------|------|------|---------------|------|------|------|---------------|------|
| | Enclosed Type (IEC IP20) | Available as standard | | | | | | | | | | | Available for option | | | | | | Not available | | | | | |
| Open Chassis Type (IEC IP00) | Available by removing the upper and lower cover of enclosed type | | | | | | | | | | | Available as standard | | | | | | | | | | | | |
| 400V Class | Model CIMR-F7Z□ | 40P4 | 40P7 | 41P5 | 42P2 | 43P7 | 45P5 | 47P5 | 4011 | 4015 | 4018 | 4022 | 4030 | 4037 | 4045 | 4055 | 4075 | 4090 | 4110 | 4132 | 4160 | 4185 | 4220 | 4300 |
| | Enclosed Type (IEC IP20) | Available as standard | | | | | | | | | | | Available for option | | | | | | | | | | Not available | |
| Open Chassis Type (IEC IP00) | Available by removing the upper and lower cover of enclosed type | | | | | | | | | | | Available as standard | | | | | | | | | | | | |

Common Specifications

| Model Number CIMR-F7Z□ | | Specification |
|---------------------------|---|--|
| Control characteristics | Control method | Sine wave PWM Closed Loop Vector control, Open Loop Vector control, V/f control, V/f with PG control |
| | Torque characteristics | Heavy Duty (low carrier, constant torque applications): 2 kHz carrier frequency, 150% overload for 1 minute, higher carrier frequency possible with current derating. Normal Duty 1 (high carrier, variable torque applications): maximum carrier frequency, depending on inverter capacity, 120% overload for 1 minute. Normal Duty 2 (variable torque applications): carrier frequency reduced, continuous overload capability increased |
| | Speed control range | 1:40 (V/f control) 1:100 (Open Loop Vector control) 1:1000 (Closed Loop Vector control) |
| | Speed control accuracy | ± 3% (V/f control) ± 0.03% (V/f control with PG) ± 0.2% (Open Loop Vector control) ± 0.02% (Closed Loop Vector control) (25°C ± 10°C) |
| | Speed control response | 5 Hz (control without PG) 30 Hz (control with PG) |
| | Torque limits | Provided (4 quadrant steps can be changed by constant settings.) (Vector control) |
| | Torque accuracy | ± 5% |
| | Frequency range | 0.01 to 150 Hz (Heavy Duty), 0.01 to 400 Hz (Normal Duty 1 or 2) |
| | Frequency accuracy (temperature characteristics) | Digital references: ± 0.01% (-10°C to +40°C) |
| | | Analog references: ± 0.1% (25°C ± 10°C) |
| | Frequency setting resolution | Digital references: 0.01 Hz |
| | | Analog references: 0.025/50 Hz (11 bits plus sign) |
| | Output frequency resolution | 0.01 Hz |
| | Overload capacity and maximum current | Heavy Duty (low carrier, constant torque applications): 150% of rated output current for 1 minute Normal Duty 1 or 2 (high/reduced carrier, variable torque applications): 120% of rated output current for 1 minute |
| | Frequency setting signal | 0 to +10V, -10 to +10 V, 4 to 20 mA, pulse train |
| Accel/Decel time | 0.01 to 6000.0 s (4 selectable combinations of independent acceleration and deceleration time settings) | |
| Braking torque | Approximately 20% (Approximately 125% with Braking Resistor option, braking transistor built into Inverters of 18.5 kW or less) | |
| Main control functions | Restarting after momentary power loss, speed search, overtorque/undertorque detection, torque limits, 17-speed control (maximum), 4 acceleration and deceleration times, S-curve acceleration/deceleration, 3-wire control, auto-tuning (rotational or stationary), dwell function, cooling fan ON/OFF control, slip compensation, torque compensation, auto-restart after fault, jump frequencies, upper and lower limits for frequency references, DC braking for starting and stopping, high-slip braking, advanced PID control, energy-saving control, MEMOBUS communications (RS-485/422, 19.2 kbps maximum), 2 motor parameter sets, fault reset and parameter copy function. | |
| Protective functions | Motor protection | Protection by electronic thermal overload relay. |
| | Instantaneous overcurrent protection | Stops at approx. 200% of rated output current. |
| | Fuse blown protection | Stops for fuse blown. |
| | Overload protection | Heavy Duty (low carrier, constant torque applications): 150% of rated output current for 1 minute Normal Duty 1 (high carrier, variable torque applications): 120% of rated output current for 1 minute Normal Duty 2 (high carrier, variable torque applications): 120% of rated output current for 1 minute, increased continuous output current. |
| | Overvoltage protection | 200 Class Inverter: Stops when main-circuit DC voltage is above 410 V. 400 Class Inverter: Stops when main-circuit DC voltage is above 820 V. |
| | Undervoltage protection | 200 Class Inverter: Stops when main-circuit DC voltage is below 190 V. 400 Class Inverter: Stops when main-circuit DC voltage is below 380 V. |
| | Momentary power loss ride through | By selecting the momentary power loss method, operation can be continued if power is restored within 2 s. |
| | Cooling fin overheating | Protection by thermistor. |
| | Stall prevention | Stall prevention during acceleration, deceleration and running independently. |
| | Grounding protection | Protection by electronic circuits. |
| Environment | Charge indicator | Glows when the main circuit DC voltage is approx. 10 VDC or more. |
| | Ambient operating temperature | -10°C to 40°C (Enclosed wall-mounted type) -10°C to 45°C (Open chassis type) |
| | Ambient operating humidity | 95% max. (with no condensation) |
| | Storage temperature | - 20°C to + 60°C (short-term temperature during transportation) |
| | Application site | Indoor (no corrosive gas, dust, etc.) |
| | Altitude | 1000 m max. |
| | Vibration | 10 to 20 Hz, 9.8 m/s ² max.; 20 to 50 Hz, 2 m/s ² max |

Dimensions

Open Chassis Type (IEC IP00)

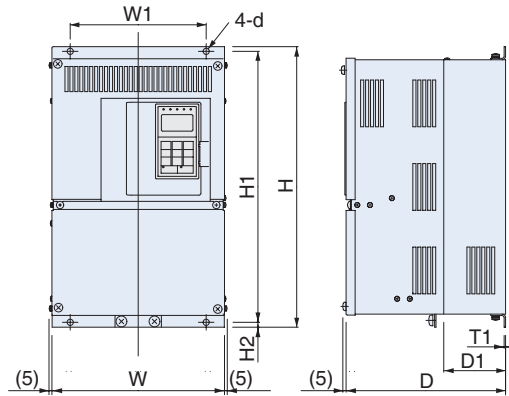

Fig 1

| Voltage | Max. Applicable Motor Output kW | Inverter CIMR-F7Z□ | Fig | Dimensions in mm | | | | | | | | | | Approx. Mass kg | Cooling Method |
|-----------------------|---------------------------------|--------------------|-----|---|-----|-----|------|------|-------|-----|-----|-----|-----|-----------------|----------------|
| | | | | W | H | D | W1 | H1 | H2 | D1 | T1 | d | | | |
| 200 V Class (3-phase) | 0.4 | ----- | 1 | Not available please use the IP20 type removing the upper and lower cover | | | | | | | | | | Fan cooled | |
| | 0.75 | ----- | | | | | | | | | | | | | |
| | 1.5 | ----- | | | | | | | | | | | | | |
| | 2.2 | ----- | | | | | | | | | | | | | |
| | 3.7 | ----- | | | | | | | | | | | | | |
| | 5.5 | ----- | | | | | | | | | | | | | |
| | 7.5 | ----- | | | | | | | | | | | | | |
| | 11 | ----- | | | | | | | | | | | | | |
| | 15 | ----- | | | | | | | | | | | | | |
| | 18.5 | ----- | | | | | | | | | | | | | |
| 22 | 2022 0 | 258 | 250 | 400 | 195 | 385 | 7.5 | 100 | 2.3 | M6 | 21 | | | | |
| 30 | 2030 0 | | 275 | 450 | 220 | 435 | | | | | 24 | | | | |
| 37 | 2037 0 | 298 | 375 | 600 | 250 | 575 | 12.5 | 100 | 3.2 | M10 | 57 | | | | |
| 45 | 2045 0 | | | | | | | | | | 328 | 63 | | | |
| 55 | 2055 0 | 348 | 450 | 725 | 325 | 700 | 15 | 130 | 4.5 | M12 | 86 | | | | |
| 75 | 2075 0 | | | | | | | | | | 87 | | | | |
| 90 | 2090 0 | 358 | 500 | 850 | 370 | 820 | 15 | 140 | 4.5 | M12 | 108 | | | | |
| 110 | 2110 0 | | | | | | | | | | 575 | 885 | 378 | 445 | 855 |
| 400 V Class (3-phase) | 0.4 | ----- | 1 | Not available please use the IP20 type removing the upper and lower cover | | | | | | | | | | Fan Cooled | |
| | 0.75 | ----- | | | | | | | | | | | | | |
| | 1.5 | ----- | | | | | | | | | | | | | |
| | 2.2 | ----- | | | | | | | | | | | | | |
| | 4.0 | ----- | | | | | | | | | | | | | |
| | 5.5 | ----- | | | | | | | | | | | | | |
| | 7.5 | ----- | | | | | | | | | | | | | |
| | 11 | ----- | | | | | | | | | | | | | |
| | 15 | ----- | | | | | | | | | | | | | |
| | 18.5 | ----- | | | | | | | | | | | | | |
| | 22 | 4022 0 | | 258 | 275 | 450 | 220 | 435 | 7.5 | 100 | 2.3 | M6 | 21 | | |
| | 30 | 4030 0 | | | 325 | 550 | 283 | 535 | | | | | 105 | | 36 |
| | 37 | 4037 0 | | 298 | 450 | 725 | 325 | 700 | 12.5 | 130 | 3.2 | M10 | 88 | | |
| | 45 | 4045 0 | | | | | | | | | | | 328 | | 89 |
| | 55 | 4055 0 | | 348 | 500 | 850 | 370 | 820 | 15 | 140 | 4.5 | M12 | 102 | | |
| 75 | 4075 0 | 120 | | | | | | | | | | | | | |
| 90 | 4090 0 | 358 | 575 | 916 | 378 | 445 | 855 | 45.8 | 140 | 4.5 | 160 | | | | |
| 110 | 4110 0 | | | | | | | | | | 260 | | | | |
| 132 | 4132 0 | 378 | 710 | 1305 | 413 | 540 | 1270 | 15 | 125.5 | 4.5 | 280 | | | | |
| 160 | 4160 0 | | | | | | | | | | 280 | | | | |
| 185 | 4185 0 | 378 | 916 | 1475 | 413 | 730 | 1440 | 15 | 125.5 | 4.5 | 405 | | | | |
| 220 | 4220 0 | | | | | | | | | | 405 | | | | |
| 300 | 4300 0 | | | | | | | | | | | | | | |

Frequency Inverters

Enclosed Type (IEC IP20)

F7Z 20P41 to F7Z25P51
F7Z40P41 to F7Z45P51

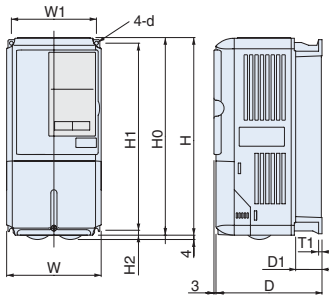

Fig 1

F7Z 27P51 to F7Z20181
F7Z47P51 to F7Z40181

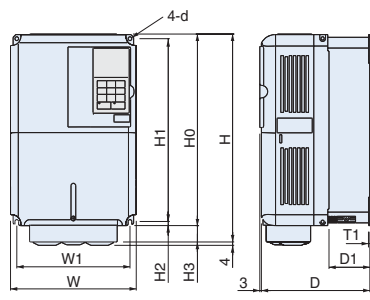

Fig 2

F7Z 20221 to F7Z20751
F7Z40221 to F7Z41601

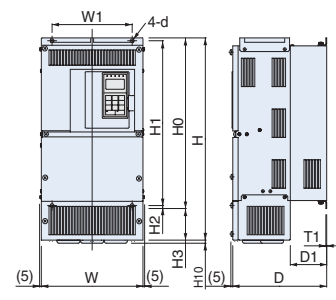
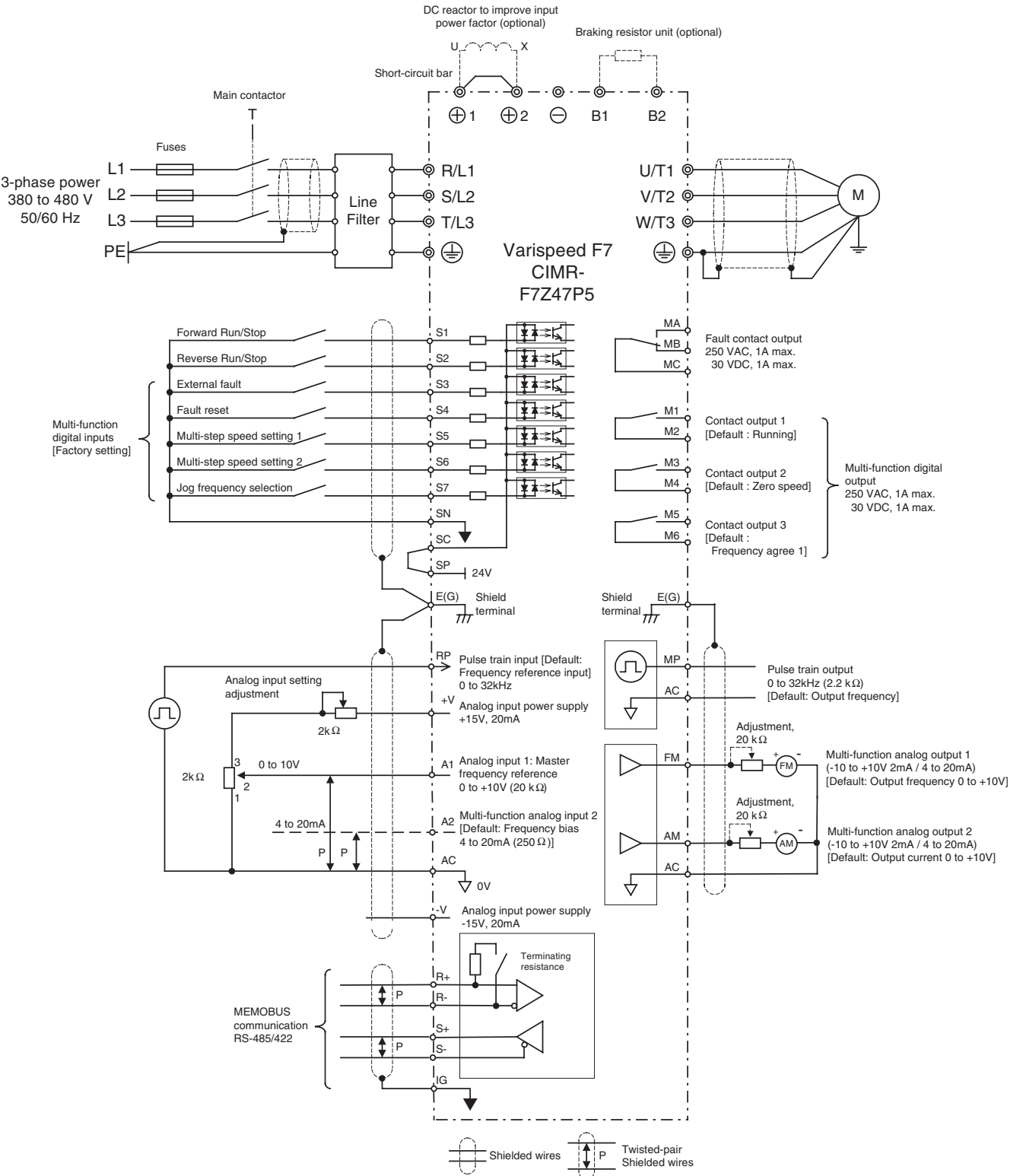

Fig 3

| Voltage | Max. Applicable Motor Output kW | Inverter CIMR-F7Z□ | Fig | Dimensions in mm | | | | | | | | | | | Approx. Mass kg | Cooling Method | | | | | | | | | | | | | |
|-----------------------|---------------------------------|--------------------|------|------------------|-----|------|-----|------|-----|-----|-----|------|-----|-----|-----------------|----------------|-----|-----|------|-----|-----|-----|-----|------|-----|-----|-----|-----|----|
| | | | | W | H | D | W1 | H0 | H1 | H2 | H3 | D1 | T1 | d | | | | | | | | | | | | | | | |
| 200 V Class (3-phase) | 0.4 | 20P4 1 | 1 | 140 | 280 | 157 | 126 | 280 | 266 | 7 | --- | 39 | 5 | M5 | 3 | Self cooled | | | | | | | | | | | | | |
| | 0.75 | 20P7 1 | | | | | | | | | | | | | | | | | | | | | | | | | | | |
| | 1.5 | 21P5 1 | | | | | | | | | | | | | | | | | | | | | | | | | | | |
| | 2.2 | 22P2 1 | | | | | | | | | | | | | | | | | | | | | | | | | | | |
| | 3.7 | 23P7 1 | | | | | | | | | | | | | | | | | | | | | | | | | | | |
| | 5.5 | 25P5 1 | 177 | 59 | | | | | | | | | | | | | | | | | | | | | | | | | |
| | 7.5 | 27P5 1 | 2 | 200 | 300 | 197 | 186 | 300 | 285 | 8 | 0 | 65.5 | 2.3 | M6 | 6 | Fan cooled | | | | | | | | | | | | | |
| | 11 | 2011 1 | | | 310 | 10 | 7 | | | | | | | | | | | | | | | | | | | | | | |
| | 15 | 2015 1 | | | 350 | 0 | 11 | | | | | | | | | | | | | | | | | | | | | | |
| | 18.5 | 2018 1 | | | 380 | 30 | 24 | | | | | | | | | | | | | | | | | | | | | | |
| | 22 | 2022 1 | 3 | 254 | 535 | 258 | 195 | 400 | 385 | 7.5 | 135 | 100 | 3.2 | M10 | 27 | Fan cooled | | | | | | | | | | | | | |
| | 30 | 2030 1 | | | 279 | 615 | 220 | 450 | 435 | | 165 | | | | | | | | | | | | | | | | | | |
| | 37 | 2037 1 | | | 380 | 809 | 298 | 250 | 600 | | 575 | | | | 12.5 | | 209 | 130 | 3.2 | M10 | 62 | | | | | | | | |
| | 45 | 2045 1 | | | | | 328 | | | | | | | | | | | | | | 68 | | | | | | | | |
| | 55 | 2055 1 | | | | | 94 | | | | | | | | | | | | | | | | | | | | | | |
| 75 | 2075 1 | 453 | 1027 | 348 | 325 | 725 | 700 | 302 | 130 | 3.2 | M10 | 95 | | | | | | | | | | | | | | | | | |
| 400 V Class (3-phase) | 0.4 | 40P4 1 | 1 | 140 | 280 | 157 | 126 | 280 | 266 | 7 | --- | 39 | 5 | M5 | 3 | Self Cooled | | | | | | | | | | | | | |
| | 0.75 | 40P7 1 | | | | | | | | | | | | | | | | | | | | | | | | | | | |
| | 1.5 | 41P5 1 | | | | | | | | | | | | | | | | | | | | | | | | | | | |
| | 2.2 | 42P2 1 | | | | | | | | | | | | | | | | | | | | | | | | | | | |
| | 3.7 | 43P7 1 | | | | | | | | | | | | | | | | | | | | | | | | | | | |
| | 4.0 | 44P0 1 | 177 | 59 | | | | | | | | | | | | | | | | | | | | | | | | | |
| | 5.5 | 45P5 1 | 2 | 200 | 300 | 197 | 186 | 300 | 285 | 8 | --- | 65.5 | 2.3 | M6 | 6 | Fan cooled | | | | | | | | | | | | | |
| | 7.5 | 47P5 1 | | | 310 | 10 | 10 | | | | | | | | | | | | | | | | | | | | | | |
| | 11 | 4011 1 | | | 350 | 0 | 24 | | | | | | | | | | | | | | | | | | | | | | |
| | 15 | 4015 1 | | | 380 | 30 | 40 | | | | | | | | | | | | | | | | | | | | | | |
| | 18.5 | 4018 1 | 3 | 275 | 535 | 258 | 220 | 450 | 435 | 7.5 | 85 | 100 | 3.2 | M10 | 24 | Fan cooled | | | | | | | | | | | | | |
| | 22 | 4022 1 | | | 325 | 715 | 283 | 260 | 550 | | 535 | | | | 105 | | 105 | | | | | | | | | | | | |
| | 30 | 4030 1 | | | | | | | | | | | | | | | | 453 | 1027 | 348 | 325 | 725 | 700 | 12.5 | 302 | 130 | 3.2 | M10 | 96 |
| | 37 | 4037 1 | | | | | | | | | | | | | | | | | | | | | | | | | | | 97 |
| | 45 | 4045 1 | | | 504 | 1243 | 358 | 370 | 850 | | 820 | | | | 15 | | 393 | 140 | 4.5 | M12 | 122 | | | | | | | | |
| | 55 | 4055 1 | 130 | | | | | | | | | | | | | | | | | | | | | | | | | | |
| | 75 | 4075 1 | 130 | | | | | | | | | | | | | | | | | | | | | | | | | | |
| | 90 | 4090 1 | 170 | | | | | | | | | | | | | | | | | | | | | | | | | | |
| 110 | 4110 1 | 579 | 1324 | 378 | 445 | 918 | 855 | 45.8 | 408 | 140 | 4.5 | M12 | 130 | | | | | | | | | | | | | | | | |
| 132 | 4132 1 | | | | | | | | | | | | 170 | | | | | | | | | | | | | | | | |
| 160 | 4160 1 | | | | | | | | | | | | 170 | | | | | | | | | | | | | | | | |

Installation

Standard Connections



Main Circuit

| Voltage | 200 V | | | 400 V | | |
|------------------------------|---|---|---------------------------------------|---|---|---------------------------------------|
| | Model CIMR-F7Z□ | 2022, 2030 | 2037 to 2110 | 40P4 to 4018 | 4022 to 4055 | 4075 to 4300 |
| Max. Applicable Motor Output | 0.4 to 18.5 kW | 22 to 30 kW | 37 to 110 kW | 0.4 to 18.5 kW | 22 to 55 kW | 75 to 300 kW |
| R/L1 | Main circuit input power supply | Main circuit input power supply | | Main circuit input power supply | Main circuit input power supply | |
| S/L2 | | | | | | |
| T/L3 | | | | | | |
| R1/L11 | | | | | | |
| S1/L21 | --- | R-R1, S-S1 and T-T1 have been wired before shipment (See P59). | | --- | R-R1, S-S1 and T-T1 have been wired before shipment | |
| T1/L31 | | | | | | |
| U/T1 | Inverter output | | | Inverter output | | |
| V/T2 | | | | | | |
| W/T3 | | | | | | |
| B1 | Braking resistor unit | ----- | | Braking resistor unit | ----- | |
| B2 | | | | | | |
| ⊕ | •DC reactor (⊕1 - ⊕2) •DC power supply ¹ (⊕1 - ⊖) | •DC power supply (⊕1 - ⊕2) ¹ •Braking unit (⊕3 - ⊖) | | •DC reactor (⊕1 - ⊕2) •DC power supply ¹ (⊕1 - ⊖) | •DC power supply (⊕1 - ⊕2) ¹ •Braking unit (⊕3 - ⊖) | |
| ⊕1 | | | | | | |
| ⊕2 | | | | | | |
| ⊕3 | --- | | | --- | | |
| ↓ / l ₂ | ----- | | Cooling fan power supply ² | --- | | |
| r/l ₁ | ----- | | | --- | | Cooling fan power supply ³ |
| ↓ 200 / l ₂ 200 | ----- | | | --- | | |
| ↓ 400 / l ₂ 400 | ----- | | | --- | | |
| ⊖ | Ground terminal (100 Ω or less) | | | Ground terminal (10 Ω or less) | | |

1. ⊕1 - ⊖ DC power input does not conform to UL/c-UL listed standard.
2. Cooling fan power supply r/l₁- ↓ / l₂: 200 to 220 VAC 50 Hz, 200 to 230 VAC 60 Hz (A transformer is required for 230 V 50 Hz or 240 V 50/60 Hz power supply.)
3. Cooling fan power supply r/l₁ - ↓ 200 / l₂ 200: 200 to 220 VAC 50 Hz, 200 to 230 VAC 60 Hz, r/l₁ - ↓ 400 / l₂ 400: 380 to 480 VAC 50/60 Hz

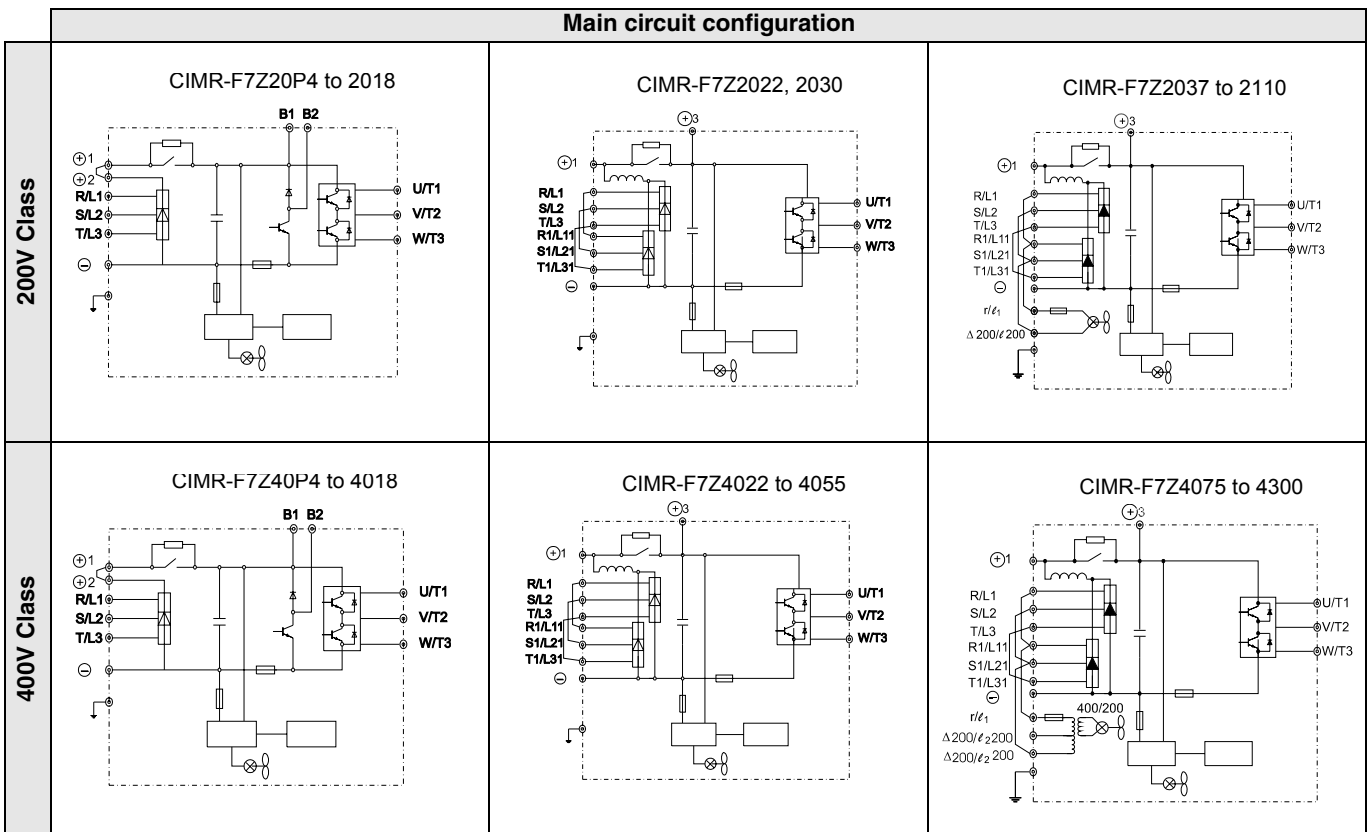

Control Circuit

| Type | No. | Signal Name | Function | Signal Level | |
|-------------------------|----------------------------|---|--|---|---|
| Digital input signals | S1 | Forward run/stop command | Forward run when ON; stopped when OFF. | 24 VDC, 8 mA Photocoupler | |
| | S2 | Reverse run/stop command | Reverse run when ON; stopped when OFF. | | |
| | S3 | External fault input ¹ | Fault when ON. | | Functions are selected by setting H1-01 to H1-05. |
| | S4 | Fault reset ¹ | Reset when ON | | |
| | S5 | Multi-step speed reference 1 ¹ (Master/auxiliary switch) | Auxiliary frequency reference when ON. | | |
| | S6 | Multi-step speed reference 2 ¹ | Multi-step setting 2 when ON. | | |
| | S7 | Jog frequency reference*1 | Jog frequency when ON. | | |
| | SC | Digital input common | – | | – |
| | SN | Digital Input Neutral | – | | – |
| SP | Digital Input Power Supply | +24VDC power supply for digital inputs | 24 VDC, 250 mA max. ² | | |
| Analog input signals | +V | 15 V power output | 15 V power supply for analog references | 15 V (Max. current: 20 mA) | |
| | –V | –15 V power output | –15 V power supply for analog references | –15 V (Max. current: 20 mA) | |
| | A1 | Frequency reference | –10 to +10 V/100% | –10 to +10 V(20 kΩ) | |
| | A2 | Multi-function analog input | 4 to 20 mA/100% –10 V to +10 V/100% | Function is selected by setting H3-09. 4 to 20 mA(250Ω) –10 V to +10 V(20kΩ) | |
| | AC | Analog reference common | – | – | |
| | E(G) | Shield wire, optional ground line connection point | – | – | |
| Sequence output signals | M1 | Running signal (1NO contact) | Operating when ON. | Multi-function contact outputs Relay contacts Contact capacity: 1 A max. at 250 VAC 1 A max. at 30 VDC ³ | |
| | M2 | | | | |
| | M3 | Zero speed | Zero level (b2-01) or below when ON | | |
| | M4 | | | | |
| | M5 | Speed agreement detection | Within ±2 Hz of set frequency when ON. | | |
| | M6 | | | | |
| | MA | Fault output signal | Fault when CLOSED across MA and MC Fault when OPEN across MB and MC | Relay contacts Contact capacity: 1 A max. at 250 VAC 1 A max. at 30 VDC ³ | |
| | MB | | | | |
| MC | | | | | |
| Analog output signals | FM | Multi-function analog output (frequency output) | 0 to 10 V, 10V=100% output frequency | Multi-function analog output 1 –10 to +10 V max. ±5% 2 mA max. | |
| | AC | Analog common | – | 4 to 20 mA current output | |
| | AM | Multi-function analog output (current monitor) | 0 to 10 V, 10V=200% inverter's rated current | | Multi-function analog output 2 |
| Pulse I/O | RP | Pulse input ⁴ | H6-01 (Frequency reference input) | 0 to 32 kHz (3 kΩ) High level voltage 3.5 to 13.2V | |
| | MP | Pulse monitor | H6-06 (Output frequency) | 0 to 32 kHz +15 V output (2.2 kΩ) | |
| RS-485/422 | R+ | MEMOBUS communications input | For 2-wire RS-485, short R+ and S+ as well as R- and S-. | Differential input, Photocoupler isolation | |
| | R- | | | | |
| | S+ | MEMOBUS communications output | | Differential input, Photocoupler isolation | |
| | S- | | | | |
| | IG | Signal common | | | – |

- * 1. The default settings are given for terminals S3 to S7. For a 3-wire sequence, the default settings are a 3-wire sequence for S5, multi-step speed setting 1 for S6 and multi-step speed setting 2 for S7.
- * 2. Do not use this power supply for supplying any external equipment.
- * 3. When driving a reactive load, such as a relay coil with DC power supply, always insert a flywheel diode
- * 4. Pulse input specifications are given in the following table

| | |
|--------------------|---------------|
| Low level voltage | 0.0 to 0.8 V |
| High level voltage | 3.5 to 13.2 V |
| H duty | 30% to 70% |
| Pulse frequency | 0 to 32 kHz |

Remove the upper and lower covers for the models of 15 kW or less in 200 V and 400 V classes.

When using open chassis type inverters of 200 V/400 V 22 kW or more, secure spaces for eyebolts and wiring of the main circuit.

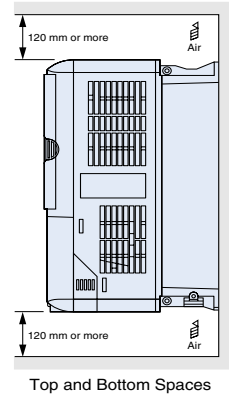
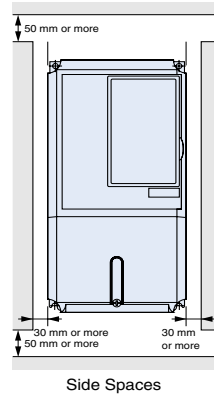
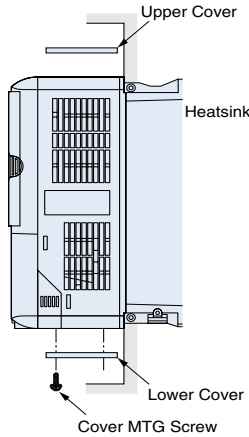
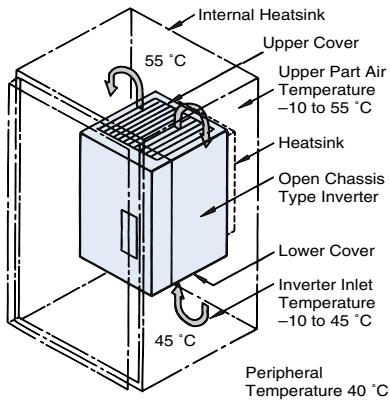

Inverter Heat Loss

200 V Class

| Model CIMR-F7Z□ | | 20P4 | 20P7 | 21P5 | 22P2 | 23P7 | 25P5 | 27P5 | 2011 | 2015 | 2018 | 2022 | 2030 | 2037 | 2045 | 2055 | 2075 | 2090 | 2110 | | |
|-------------------|-----------------|-------------|------|------|------|------|------|------------|------|------|------|------|------|------|------|------|------|------|------|------|--|
| Inverter Capacity | kVA | 1.2 | 1.6 | 2.7 | 3.7 | 5.7 | 8.8 | 12 | 17 | 22 | 27 | 32 | 44 | 55 | 69 | 82 | 110 | 130 | 160 | | |
| Rated Current | A | 3.2 | 4.1 | 7.0 | 9.6 | 15 | 23 | 31 | 45 | 58 | 71 | 85 | 115 | 145 | 180 | 215 | 283 | 346 | 415 | | |
| Heat Loss W | Fin | W | 20 | 27 | 50 | 70 | 112 | 164 | 219 | 374 | 429 | 501 | 586 | 865 | 1015 | 1266 | 1588 | 2019 | 2437 | 2733 | |
| | Inside Unit | W | 39 | 42 | 50 | 59 | 74 | 84 | 113 | 170 | 183 | 211 | 274 | 352 | 411 | 505 | 619 | 838 | 997 | 1242 | |
| | Total Heat Loss | W | 59 | 69 | 100 | 129 | 186 | 248 | 332 | 544 | 612 | 712 | 860 | 1217 | 1426 | 1771 | 2207 | 2857 | 3434 | 3975 | |
| Fin Coding | | Self cooled | | | | | | Fan cooled | | | | | | | | | | | | | |

400 V Class

| Model CIMR-F7Z□ | | 40P4 | 40P7 | 41P5 | 42P2 | 43P7 | 44P0 | 45P5 | 47P5 | 4011 | 4015 | 4018 | 4022 | 4030 | 4037 | 4045 | 4055 | 4075 | 4090 | 4110 | 4132 | 4160 | 4185 | 4220 | 4300 | |
|-------------------|-----------------|-------------|------|------|------|------|------|------------|------|------|------|------|------|------|------|------|------|------|------|------|------|------|------|------|------|------|
| Inverter Capacity | kVA | 1.4 | 1.6 | 2.8 | 4.0 | 5.8 | 6.0 | 9.5 | 13 | 18 | 24 | 30 | 34 | 46 | 57 | 69 | 85 | 110 | 140 | 160 | 200 | 230 | 280 | 390 | 510 | |
| Rated Current | A | 1.8 | 2.1 | 3.7 | 5.3 | 7.6 | 8.0 | 12.5 | 17 | 24 | 31 | 39 | 45 | 60 | 75 | 91 | 112 | 150 | 180 | 216 | 260 | 304 | 370 | 506 | 675 | |
| Heat Loss W | Fin | W | 14 | 17 | 36 | 59 | 80 | 91 | 127 | 193 | 252 | 326 | 426 | 466 | 678 | 784 | 901 | 1203 | 1399 | 1614 | 2097 | 2388 | 2791 | 3237 | 3740 | 5838 |
| | Inside Unit | W | 39 | 41 | 48 | 56 | 68 | 70 | 82 | 114 | 158 | 172 | 208 | 259 | 317 | 360 | 415 | 495 | 575 | 671 | 853 | 1002 | 1147 | 1372 | 1537 | 2320 |
| | Total Heat Loss | W | 53 | 58 | 84 | 115 | 148 | 161 | 209 | 307 | 410 | 498 | 634 | 725 | 995 | 1144 | 1316 | 1698 | 1974 | 2285 | 2950 | 3390 | 3938 | 4609 | 5277 | 8158 |
| Fin Coding | | Self cooled | | | | | | Fan cooled | | | | | | | | | | | | | | | | | | |

Attachments

Heatsink External Mounting Attachment

The Varispeed F7 inverters under the 200/400 V class 18.5 kW or less need this attachment for mounting the heatsink externally. This attachment expands the outer dimensions of the width and height of the inverter. (Attachment is not required for inverters of 22 kW or more.)

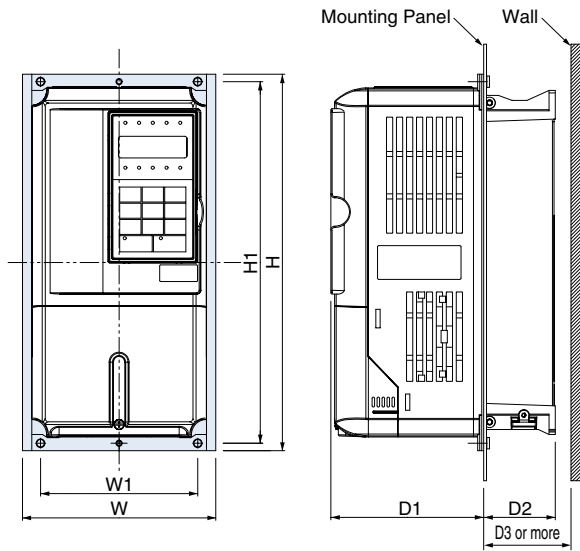

| CIMR-F7Z□ | Attachment Order Code | Dimensions in mm | | | | | | |
|-----------|-----------------------|------------------|-----|-----|-----|-------|------|----|
| | | W | H | W1 | H1 | D1 | D2 | D3 |
| 20P4 | 72616-EZZ08676A | 155 | 302 | 126 | 290 | 122.6 | 37.4 | 40 |
| 20P7 | | | | | | | | |
| 21P5 | | | | | | | 57.4 | 60 |
| 22P2 | | | | | | | | |
| 23P7 | | | | | | | | |
| 25P5 | 72616-EZZ08676B | 210 | 330 | 180 | 316 | 136.1 | 63.4 | 70 |
| 27P5 | | | | | | | | |
| 2011 | | | | | | | | |
| 2015 | 72616-EZZ08676C | 250 | 392 | 216 | 372 | 133.6 | 76.4 | 85 |
| 2018 | | | | | | | | |
| 40P4 | 72616-EZZ08676A | 155 | 302 | 126 | 290 | 122.6 | 37.4 | 40 |
| 40P7 | | | | | | | | |
| 41P5 | | | | | | | 57.4 | 60 |
| 42P2 | | | | | | | | |
| 43P7 | | | | | | | | |
| 44P0 | | | | | | | | |
| 45P5 | 72616-EZZ08676B | 210 | 330 | 180 | 316 | 136.1 | 63.4 | 70 |
| 47P5 | | | | | | | | |
| 4011 | | | | | | | | |
| 4015 | 72616-EZZ08676C | 250 | 392 | 216 | 372 | 133.6 | 76.4 | 85 |
| 4018 | | | | | | | | |

Frequency Inverters

Panel Cut for External Mounting of Cooling Fin (Heatsink)

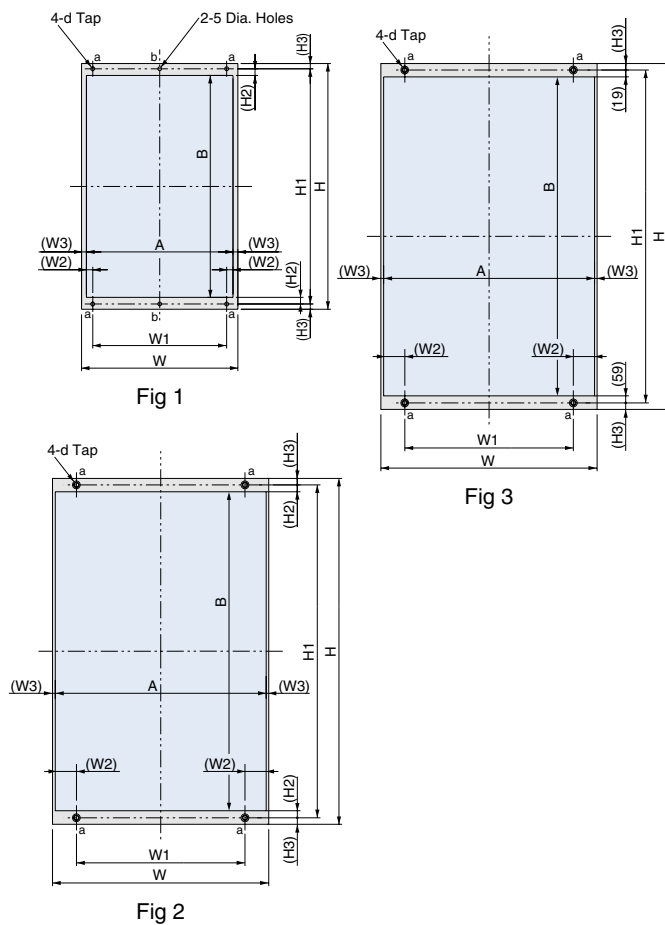

| CIMR-F7Z□ | Fig | Dimensions in mm | | | | | | | | | | | | | | | | | | | | | |
|-----------|-----|------------------|-----|-----|------|------|-----|------|------|-----|-----|----|------|------|-----|-----|------|-----|-----|-----|-----|-----|-----|
| | | W | H | W1 | (W2) | (W3) | H1 | (H2) | (H3) | A | B | d | | | | | | | | | | | |
| 20P4 | 1 | 155 | 302 | 126 | 6 | 8.5 | 290 | 9.5 | 6 | 138 | 271 | M5 | | | | | | | | | | | |
| 20P7 | | | | | | | | | | | | | | | | | | | | | | | |
| 21P5 | | | | | | | | | | | | | | | | | | | | | | | |
| 22P2 | | | | | | | | | | | | | | | | | | | | | | | |
| 23P7 | | | | | | | | | | | | | | | | | | | | | | | |
| 25P5 | | | | | | | | | | | | | | | | | | | | | | | |
| 27P5 | | | | | | | | | | | | | 8.5 | 6.5 | 316 | 9 | 7 | 197 | 298 | | | | |
| 2011 | | | | | | | | | | | | | | | | | | | | | | | |
| 2015 | | | | | | | | | | | | | | | | | | | | | | | |
| 2018 | | | | | | | | | | | | | | | | | | | | | | | |
| 2022 | 2 | 250 | 400 | 195 | 24.5 | 3 | 385 | 8 | 7.5 | 244 | 369 | M6 | | | | | | | | | | | |
| 2030 | | | | | | | | | | | | | | | | | | | | | | | |
| 2037 | | | | | | | | | | | | | | | | | | | | | | | |
| 2045 | | | | | | | | | | | | | 54.5 | 8 | 575 | 15 | 12.5 | 359 | 545 | | | | |
| 2055 | | | | | | | | | | | | | | | | | | | | | | | |
| 2075 | | | | | | | | | | | | | 700 | 13.5 | 434 | 673 | | | | | | | |
| 2090 | | | | | | | | | | | | | | | | | | | | | | | |
| 2110 | | | | | | | | | | | | | 500 | 850 | 370 | 57 | 8 | 820 | 19 | 15 | 484 | 782 | M12 |
| 40P4 | | | | | | | | | | | | | | | | | | | | | | | |
| 40P7 | | | | | | | | | | | | | 1 | 155 | 302 | 126 | 6 | 8.5 | 290 | 9.5 | 6 | 138 | 271 |
| 41P5 | | | | | | | | | | | | | | | | | | | | | | | |
| 42P2 | | | | | | | | | | | | | | | | | | | | | | | |
| 43P7 | | | | | | | | | | | | | | | | | | | | | | | |
| 44P0 | | | | | | | | | | | | | | | | | | | | | | | |
| 45P5 | | | | | | | | | | | | | | | | | | | | | | | |
| 47P5 | 8.5 | 6.5 | 316 | 9 | 7 | 197 | 298 | | | | | | | | | | | | | | | | |
| 4011 | | | | | | | | | | | | | | | | | | | | | | | |
| 4015 | | | | | | | | | | | | | | | | | | | | | | | |
| 4018 | | | | | | | | | | | | | | | | | | | | | | | |
| 4022 | 2 | 275 | 450 | 220 | 24.5 | 3 | 435 | 8 | 7.5 | 269 | 419 | M6 | | | | | | | | | | | |
| 4030 | | | | | | | | | | | | | | | | | | | | | | | |
| 4037 | | | | | | | | | | | | | | | | | | | | | | | |
| 4045 | | | | | | | | | | | | | 54.5 | 8 | 535 | 8 | 7.5 | 309 | 519 | | | | |
| 4055 | | | | | | | | | | | | | | | | | | | | | | | |
| 4075 | | | | | | | | | | | | | 700 | 13.5 | 434 | 673 | | | | | | | |
| 4090 | | | | | | | | | | | | | | | | | | | | | | | |
| 4110 | | | | | | | | | | | | | 500 | 850 | 370 | 57 | 8 | 820 | 19 | 15 | 484 | 782 | M12 |
| 4132 | | | | | | | | | | | | | | | | | | | | | | | |
| 4160 | | | | | | | | | | | | | 3 | 575 | 925 | 445 | 55 | 10 | 895 | 1 | 15 | 555 | 817 |

1. The sizes are different between the top and the bottom. Refer Fig 3

Ordering Information

System Configuration

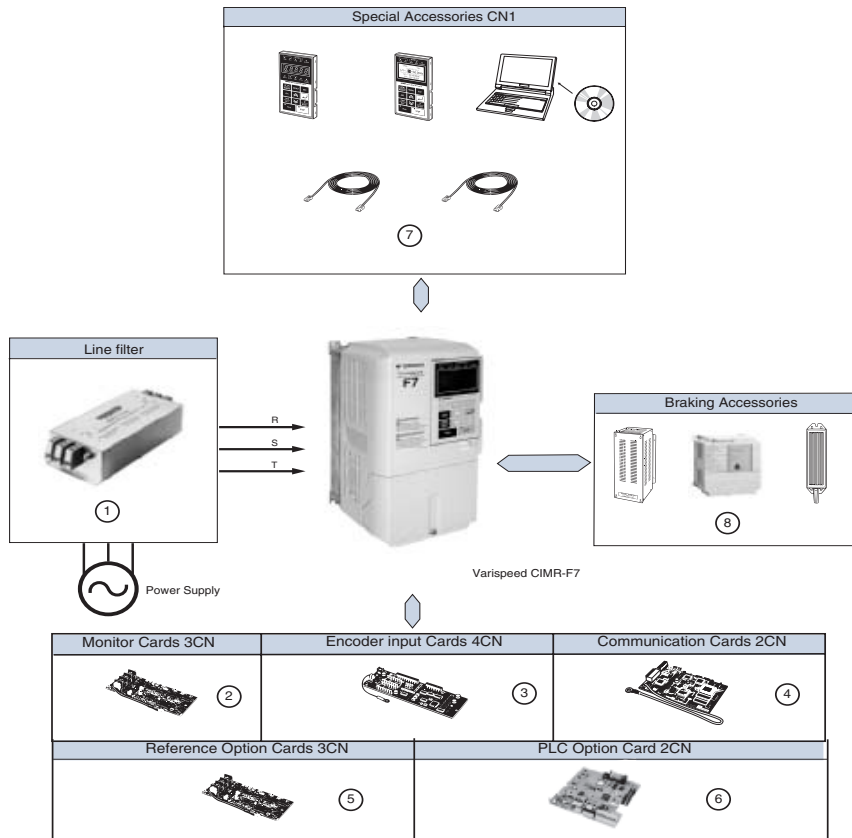

① Line Filters





200 V

| Inverter Model | Line Filters | | | | | |
|----------------|------------------|------|---------------------|-------------|-------------|----------------------|
| | Varispeed F7 | Type | EN55011 Class | Current (A) | Weight (kg) | Dimensions W x D x H |
| CIMR-F7Z20P4 | 3G3RV-PFI3010-SE | | B, 25 m A, 100 m | 10 | 1.1 | 141x45x330 |
| CIMR-F7Z20P7 | | | | | | |
| CIMR-F7Z21P5 | | | | | | |
| CIMR-F7Z22P2 | 3G3RV-PFI3018-SE | | B, 25 m A, 100 m | 18 | 1.3 | 141x46x330 |
| CIMR-F7Z23P7 | | | | | | |
| CIMR-F7Z25P5 | 3G3RV-PFI2035-SE | | B, 25 m A, 100 m | 35 | 1.4 | 141x46x330 |
| CIMR-F7Z27P5 | | | | | | |
| CIMR-F7Z2011 | 3G3RV-PFI2060-SE | | B, 25 m A, 100 m | 60 | 3 | 206x60x355 |
| CIMR-F7Z2015 | | | | | | |
| CIMR-F7Z2018 | 3G3RV-PFI2100-SE | | B, 25 m A, 100 m | 100 | 4.9 | 236x80x408 |
| CIMR-F7Z2022 | | | | | | |
| CIMR-F7Z2030 | 3G3RV-PFI2130-SE | | A, 100 m | 130 | 4.3 | 90x180x366 |
| CIMR-F7Z2037 | | | | | | |
| CIMR-F7Z2045 | 3G3RV-PFI2160-SE | | A, 100 m | 160 | 6.0 | 120x170x451 |
| CIMR-F7Z2055 | | | | | | |
| CIMR-F7Z2075 | 3G3RV-PFI2200-SE | | A, 100 m | 200 | 11.0 | 130x240x610 |
| CIMR-F7Z2090 | | | | | | |
| CIMR-F7Z2110 | 3G3RV-PFI3600-SE | | A, 100 m | 600 | 11.0 | 260x135x386 |

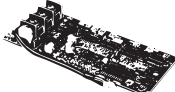
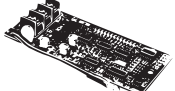
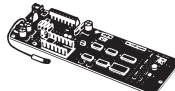
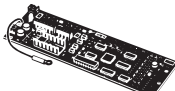
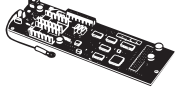
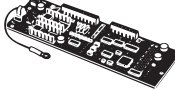
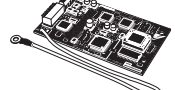

400 V

| Inverter Model | Line Filter | | | | | |
|----------------|------------------|-------|---------------------|-------------|-------------|----------------------|
| | Varispeed F7 | Model | EN 55011 Class* | Current (A) | Weight (kg) | Dimensions W x D x H |
| CIMR-F7Z40P4 | 3G3RV-PFI3010-SE | | B, 25 m A, 100 m | 10 | 1.1 | 141x46x330 |
| CIMR-F7Z40P7 | | | | | | |
| CIMR-F7Z41P5 | | | | | | |
| CIMR-F7Z42P2 | 3G3RV-PFI3018-SE | | B, 25 m A, 100 m | 18 | 1.3 | 141x46x330 |
| CIMR-F7Z43P7 | | | | | | |
| CIMR-F7Z44P0 | 3G3RV-PFI3035-SE | | B, 25 m A, 100 m | 35 | 2.1 | 206x50x355 |
| CIMR-F7Z45P5 | | | | | | |
| CIMR-F7Z47P5 | 3G3RV-PFI3060-SE | | B, 25 m A, 100 m | 60 | 4.0 | 236x65x408 |
| CIMR-F7Z4011 | | | | | | |
| CIMR-F7Z4015 | 3G3RV-PFI3070-SE | | A, 100 m | 70 | 3.4 | 80x185x329 |
| CIMR-F7Z4018 | | | | | | |
| CIMR-F7Z4022 | 3G3RV-PFI3130-SE | | A, 100 m | 130 | 4.7 | 90x180x366 |
| CIMR-F7Z4030 | | | | | | |
| CIMR-F7Z4037 | 3G3RV-PFI3170-SE | | A, 100 m | 170 | 6.0 | 120x170x451 |
| CIMR-F7Z4045 | | | | | | |
| CIMR-F7Z4055 | 3G3RV-PFI3200-SE | | A, 100 m | 250 | 11 | 130x240x610 |
| CIMR-F7Z4075 | | | | | | |
| CIMR-F7Z4090 | 3G3RV-PFI3400-SE | | A, 100 m | 400 | 18.5 | 300x160x610 |
| CIMR-F7Z4110 | | | | | | |
| CIMR-F7Z4132 | 3G3RV-PFI3600-SE | | A, 100 m | 600 | 11,0 | 260x135x386 |
| CIMR-F7Z4160 | | | | | | |
| CIMR-F7Z4185 | 3G3RV-PFI3800-SE | | A, 100 m | 800 | 31.0 | 300x160x716 |
| CIMR-F7Z4220 | | | | | | |
| CIMR-F7Z4300 | | | | | | |

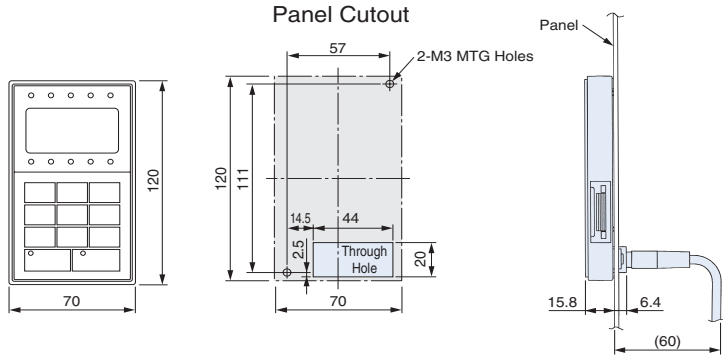

Ordering Information

| Type | Name | Description | Function |
|----------------------------------|--|---|--|
| ② Monitor option card | AO-08 / 3G3IV-PAO08  | Analog monitor card | Outputs analog signal for monitoring inverter output state (output freq., output current etc.) after absolute value conversion. • Output resolution: 8 bits (1/256) • Output voltage: 0 to {10 V (non isolated) EOutput channel: 2 channels |
| | AO-12 / 3G3IV-PAO12  | | Outputs analog signal for monitoring inverter output state (output freq., output current etc.) • Output resolution: 11 bits (1/2048) + code • Output voltage: 110 to {10 V (non isolated) EOutput channel: 2 channels |
| | DO-08 / 3G3IV-PDO08 | Digital output card | Outputs isolated type digital signal for monitoring inverter run state (alarm signal, zero speed detection etc.) . Output channel: Photo coupler 6 channels (48 V, 50 mA or less) Relay contact output 2 channels (250 VAC, 1 A or less 30 VDC, 1 A or less) |
| | DO-02C / 3G3IV-PDO02C | 2C-relay output card | • Two multi-function contact outputs (2C-relay) can be used other than those of the inverter proper unit. |
| ③ Feedback Speed Control Card | PG-A2 / 3G3FV-PPGA2  | PG Speed Controller Card (Used for V/f control with PG or Flux Vector) | • Phase A pulse (single pulse) inputs (voltage, complementary, open collector input) • PG frequency range: Approx. 30 kHz max. [Power supply output for PG: +12 V, max. current 200 mA] Pulse monitor output: +12 V, 20 mA |
| | PG-B2 / 3G3FV-PPGB2  | | • Phase A and B pulse inputs (exclusively for complementary input) • PG frequency range: Approx. 30 kHz max. [Power supply output for PG: +12 V, Max. current 200 mA] • Pulse monitor output: Open collector, +24 V, Max. current 30 mA |
| | PG-D2 / 3G3FV-PPGD2  | | • Phase A pulse (differential pulse) input for V/f control (RS-422 input) • PG frequency range: Approx. 300 kHz max. [Power supply output for PG: +5 V or +12 V, Max. current 200 mA] • Pulse monitor output: RS-422 |
| | PG-X2 / 3G3FV-PPGX2  | | • Phase A, B and Z pulse (differential pulse) inputs (RS-422 input) • PG frequency range: Approx. 300 kHz max. [Power supply output for PG: +5 V or +12 V, Max. current 200 mA] • Pulse monitor output: RS-422 |
| ④ Communication option card | 3G3RV-PDRT2  | DeviceNet option card | • Used for running or stopping the inverter, setting or referencing parameters, and monitoring output frequency, output current, or similar items through DeviceNet communication with the host controller. |
| | SI-P1 | Profibus-DP option card | • Used for running or stopping the inverter, setting or referencing parameters, and monitoring output frequency, output current, or similar items through Profibus-DP communication with the host controller. |
| | SI-S1 | CANopen option card | • Used for running or stopping the inverter, setting or referencing parameters, and monitoring output frequency, output current, or similar items through CANopen communication with the host controller. |
| | SI-J | LONWORKS option card | • Used for HVAC control, running or stopping the inverter, setting or referencing parameters, and monitoring output current, watt-hours, or similar items through LONWORKS communications with peripheral devices. |
| ⑤ Reference option card | AI-14U / 3G3IV-PAI14U | Analog input card | • 2 channel high resolution analog input card • Channel 1: 0 to 10 V (20K Ω) • Channel 2: 4 to 20 mA (250 Ω) • Resolution 14 bit |
| | AI-14B / 3G3IV-PAI14B | | • 3 Channel high resolution analog input card • Signal level: -10 to +10V (20 K Ω) • 4 to 20 mA (250 Ω) • Resolution: 13 bit + sign |
| | DI-08 / 3G3IV-PDI08 | Digital reference card | • 8 bit digital speed reference input card |
| | DI-16H2 / 3G3IV-PDI16H2 | | • 16 bit digital speed reference input card |
| ⑥ PLC option | 3G3RV-P10ST8-E  | PLC option | • Full PLC features, wireless installation and seamless access to the inverter parameters and analogue/digital inputs and outputs. • Embedded Compubus/S fieldbus • Standard Omron tools can be used for programming |
| | 3G3RV-P10ST8-DRT-E | PLC option with DeviceNet | • Same features than standard model with DeviceNet support. |

⑦ Accessories

| | Name | Description | Installation |
|------------------|--|--|---|
| Digital operator | JVOP-160-OY  | 5 lines LCD digital operator 7 Language support | <p>Panel Cutout</p>  <p>Panel Cutout installation</p> |
| | JVOP-161-OY  | 7 segment LED digital operator | |
| Accessories | 3G3IV-PCN126 3G3IV-PCN326 | Digital operator extension cable 1 meters 3 meters | ---- |
| | 3G3IV-PCN329-E | PC configuration cable | ---- |
| | Sysdrive Configurator | Computer software | Configuration and monitoring software tool |
| | User's manual | YEG-TOE-S616-55.1-OY | ---- |

⑧ Braking Unit, Braking Resistor Unit

| Inverter | | | Braking unit  | | Braking Resistor Unit ¹ | | | | | | | | |
|-------------|---------------------------------|-----------------|---|-------------|---|---------------|-------------|------------------|--|----------------------------|-------------|------------------|------------------------------------|
| | | | | | Inverter-mounted Type (3 %ED, 10 sec max) ²  | | | | Separately-installed Type (10 %ED, 10 sec. max.) ³  | | | | |
| Voltage | Max. Applicable Motor output kW | Model CIMR-F7Z_ | Model CDBR_ | No. of used | Model ERF-150WJ_ | Resistance | No. of used | Braking torque % | Model LKEB_ | Specifications of Resistor | No. of used | Braking torque % | Connectable Min Resistance Value Ω |
| 200 V Class | 0.4 | 20P4 | Built-in | --- | 201 | 200 Ω | 1 | 220 | 20P7 | 70 W 200 Ω | 1 | 220 | 48 |
| | 0.75 | 20P7 | | | 201 | 200 Ω | 1 | 125 | 20P7 | 70 W 200 Ω | 1 | 125 | 48 |
| | 1.5 | 21P5 | | | 101 | 100 Ω | 1 | 125 | 21P5 | 260 W 100 Ω | 1 | 125 | 48 |
| | 2.2 | 22P2 | | | 700 | 70 Ω | 1 | 120 | 22P2 | 260 W 70 Ω | 1 | 120 | 16 |
| | 3.7 | 23P7 | | | 620 | 62 Ω | 1 | 100 | 23P7 | 390 W 40 Ω | 1 | 125 | 16 |
| | 5.5 | 25P5 | | | 25P5 | 520 W 30 Ω | 1 | 115 | 16 | | | | |
| | 7.5 | 27P5 | | | 27P5 | 780 W 20 Ω | 1 | 125 | 9.6 | | | | |
| | 11 | 2011 | | | 2011 | 2400 W 13.6 Ω | 1 | 125 | 9.6 | | | | |
| | 15 | 2015 | | | 2015 | 3000 W 10 Ω | 1 | 125 | 9.6 | | | | |
| | 18.5 | 2018 | | | 2015 | 3000 W 10 Ω | 1 | 125 | 9.6 | | | | |
| | 22 | 2022 | | | 2022 | 4800 W 6.8 Ω | 1 | 125 | 6.4 | | | | |
| | 30 | 2030 | | | 2015B | 2 | 125 | 9.6 | | | | | |
| | 37 | 2037 | | | 2015B | 2 | 100 | 9.6 | | | | | |
| | 45 | 2045 | | | 2022B | 2 | 120 | 6.4 | | | | | |
| | 55 | 2055 | | | 2022B | 2 | 100 | 6.4 | | | | | |
| | 75 | 2075 | | | 2110B | 1 | 110 | 1.6 | | | | | |
| | 90 | 2090 | | | 2110B | 1 | 120 | 1.6 | | | | | |
| | 110 | 2110 | | | 2110B | 1 | 100 | 1.6 | | | | | |
| 400 V Class | 0.4 | 40P4 | Built in | --- | 751 | 750 Ω | 1 | 230 | 40P7 | 70 W 750 Ω | 1 | 230 | 96 |
| | 0.75 | 40P7 | | | 751 | 750 Ω | 1 | 130 | 40P7 | 70 W 750 Ω | 1 | 130 | 96 |
| | 1.5 | 41P5 | | | 401 | 400 Ω | 1 | 125 | 41P5 | 260 W 400 Ω | 1 | 125 | 64 |
| | 2.2 | 42P2 | | | 301 | 300 Ω | 1 | 115 | 42P2 | 260 W 250 Ω | 1 | 135 | 64 |
| | 3.7 | 43P7 | | | 201 | 200 Ω | 1 | 110 | 43P7 | 390 W 150 Ω | 1 | 135 | 32 |
| | 4.0 | 44P0 | | | 45P5 | 520 W 100 Ω | 1 | 135 | 32 | | | | |
| | 5.5 | 45P5 | | | 47P5 | 780 W 75 Ω | 1 | 130 | 32 | | | | |
| | 7.5 | 47P5 | | | 4011 | 1040 W 50 Ω | 1 | 135 | 20 | | | | |
| | 11 | 4011 | | | 4015 | 1560 W 40 Ω | 1 | 125 | 20 | | | | |
| | 15 | 4015 | | | 4018 | 4800 W 32 Ω | 1 | 125 | 19.2 | | | | |
| | 18.5 | 4018 | | | 4022 | 4800 W 27.2 Ω | 1 | 125 | 19.2 | | | | |
| | 22 | 4022 | | | 4030B | 1 | 125 | 19.2 | | | | | |
| | 30 | 4030 | | | 4030B | 1 | 125 | 19.2 | | | | | |
| | 37 | 4037 | | | 4045B | 1 | 125 | 12.8 | | | | | |
| | 45 | 4045 | | | 4045B | 1 | 125 | 12.8 | | | | | |
| | 55 | 4055 | | | 4030B | 2 | 135 | 19.2 | | | | | |
| | 75 | 4075 | | | 4045B | 2 | 145 | 12.8 | | | | | |
| | 90 | 4090 | | | 4220B | 1 | 100 | 3.2 | | | | | |
| | 110 | 4110 | | | 4220B | 1 | 100 | 3.2 | | | | | |
| | 132 | 4132 | | | 4220B | 1 | 140 | 3.2 | | | | | |
| 160 | 4160 | 4220B | 1 | 140 | 3.2 | | | | | | | | |
| 185 | 4185 | 4220B | 1 | 120 | 3.2 | | | | | | | | |
| 220 | 4220 | 4220B | 1 | 110 | 3.2 | | | | | | | | |
| 300 | 4300 | 4220B | 2 | 110 | 3.2 | | | | | | | | |

- When connecting a mounting type resistor or braking resistor unit, set system constant L3-04 to 0 (stall prevention disabled during deceleration). If operating without changing the constant, motor does not stop at set deceleration time.
- When connecting mounting type braking resistor, set system constant L8-01 to 1 (braking resistor protection enabled).
- Load factor during deceleration to stop a load with constant torque. With constant output or continuous regenerative braking, the load factor is smaller than the specified value.
- Resistance value per one braking unit. Select a resistance value that is larger than connectable minimum resistance value to obtain enough braking torque.
- For an application with large regenerative power such as hoisting, the braking torque or other items may exceed the capacity of a braking unit with a braking resistor in a standard combination (an result in capacity overload). Contact your Omron representatives when the braking torque or any other item exceeds the values in the table.

Frequency Inverters

Connections for braking units

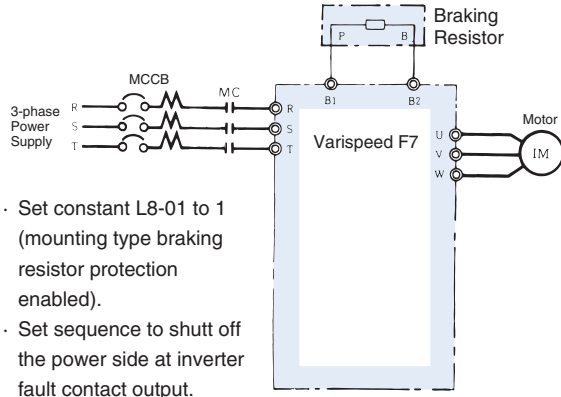

- Set constant L8-01 to 1 (mounting type braking resistor protection enabled).
- Set sequence to shutt off the power side at inverter fault contact output.

Connections for braking resistors

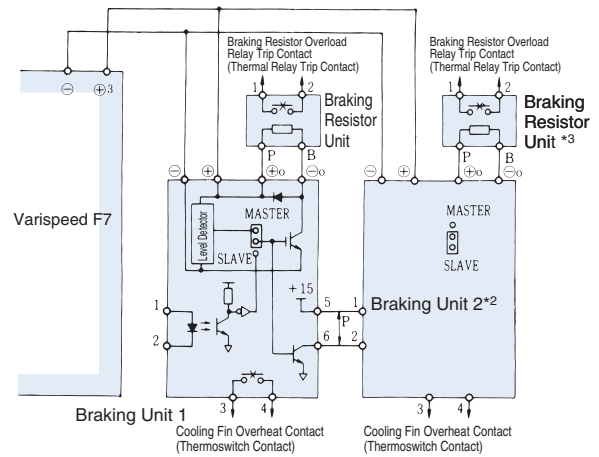

Braking Unit

| Model CDBR-2015 B, -2022 B, -4030B, -4045 B | Model CDBR-2110 B |
|---|--------------------|
| <p>Mass 1.8 Kg</p> | <p>Mass 8.5 Kg</p> |
| Model CDBR-4220 B | |
| <p>Mass 12 Kg</p> | |

Braking Resistor Unit (Inverter-mounted Type)



Mass: 0.2 kg
Model ERF-150WJ_

Note: Prepare mounting screws (2-M4x8 tapped screws). Screws 8mm or more and general metric screws cannot be used.

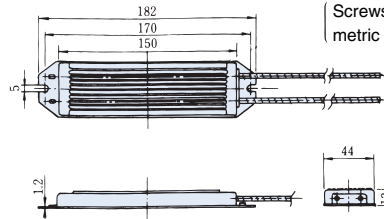

Braking Resistor Unit (Separately-installed Type)

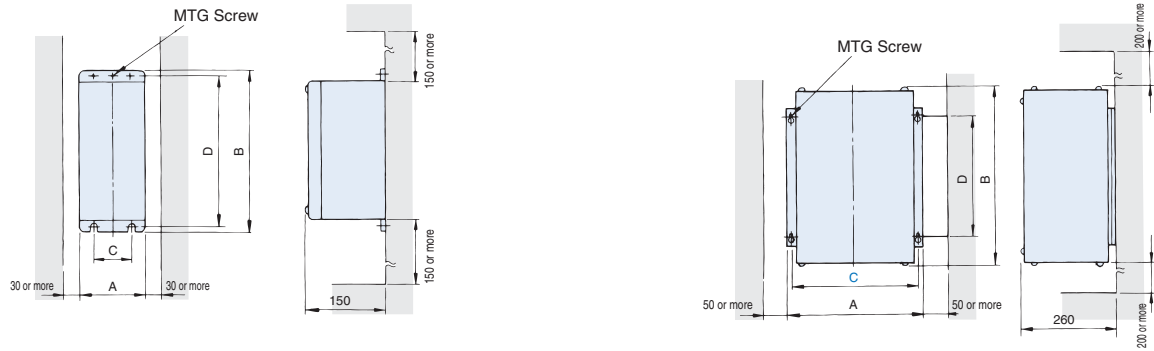

| Voltage | Model LKEB- | Dimensions in mm | | | | | Mass kg |
|-------------|-------------|------------------|-----|-----|-----|-----------|---------|
| | | A | B | C | D | MTG Screw | |
| 220 V Class | 20P7 | 105 | 275 | 50 | 260 | M5 x 3 | 3.0 |
| | 21P5 | 130 | 350 | 75 | 335 | M5 x 4 | 4.5 |
| | 22P2 | 130 | 350 | 75 | 335 | M5 x 4 | 4.5 |
| | 23P7 | 130 | 350 | 75 | 335 | M5 x 4 | 5.0 |
| | 25P5 | 250 | 350 | 200 | 335 | M6 x 4 | 7.5 |
| 400 V Class | 25P5 | 250 | 350 | 200 | 335 | M6 x 4 | 8.5 |
| | 40P7 | 105 | 275 | 50 | 260 | M5 x 3 | 3.0 |
| | 41P5 | 130 | 350 | 75 | 335 | M5 x 4 | 4.5 |
| | 42P2 | 130 | 350 | 75 | 335 | M5 x 4 | 4.5 |
| | 43P7 | 130 | 350 | 75 | 335 | M5 x 4 | 5.0 |
| | 45P5 | 250 | 350 | 200 | 332 | M6 x 4 | 7.5 |
| | 47P5 | 250 | 350 | 200 | 332 | M6 x 4 | 8.5 |

| Voltage | Model LKEB- | Dimensions in mm | | | | | Mass kg |
|-------------|-------------|------------------|-----|-----|--------|-----------|---------|
| | | A | B | C | D | MTG Screw | |
| 220 V Class | 2011 | 266 | 543 | 246 | 340 | M8 x 4 | 10 |
| | 2015 | 356 | 543 | 336 | 340 | M8 x 4 | 15 |
| | 2018 | 446 | 543 | 426 | 340 | M8 x 4 | 19 |
| | 2022 | 446 | 543 | 426 | 340 | M8 x 4 | 19 |
| 400 V Class | 4011 | 350 | 412 | 330 | 325 | M6 x 4 | 16 |
| | 4015 | 350 | 412 | 330 | 325 | M6 x 4 | 18 |
| | 4018 | 446 | 543 | 426 | 340 | M8 x 4 | 19 |
| | 4022 | 446 | 543 | 426 | 340 | M8 x 4 | 19 |
| | 4030 | 356 | 956 | 336 | 740 | M8 x 4 | 25 |
| | 4037 | 446 | 956 | 426 | 740 | M8 x 4 | 33 |
| 4045 | 446 | 956 | 426 | 740 | M8 x 4 | 33 | |

Frequency Inverters

AC Reactor

Connection Example

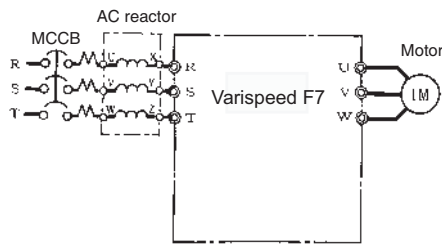

Application Example

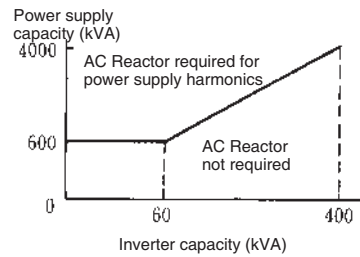

| 200 V Class | | | | 400 V Class | | | |
|---------------------------------|-----------------|---------------|----------|---------------------------------|-----------------|---------------|----------|
| Max. Applicable Motor Output kW | Current Value A | Inductance mH | Code No. | Max. Applicable Motor Output kW | Current Value A | Inductance mH | Code No. |
| 0.4 | 2.5 | 4.2 | X 002553 | 0.4 | 1.3 | 18.0 | X 002561 |
| 0.75 | 5 | 2.1 | X 002554 | 0.75 | 2.5 | 8.4 | X 002562 |
| 1.5 | 10 | 1.1 | X 002489 | 1.5 | 5 | 4.2 | X 002563 |
| 2.2 | 15 | 0.71 | X 002490 | 2.2 | 7.5 | 3.6 | X 002564 |
| 3.7 | 20 | 0.53 | X 002491 | 3.7 | 10 | 2.2 | X 002500 |
| 5.5 | 30 | 0.35 | X 002492 | 5.5 | 15 | 1.42 | X 002501 |
| 7.5 | 40 | 0.265 | X 002493 | 7.5 | 20 | 1.06 | X 002502 |
| 11 | 60 | 0.18 | X 002495 | 11 | 30 | 0.7 | X 002503 |
| 15 | 80 | 0.13 | X 002497 | 15 | 40 | 0.53 | X 002504 |
| 18.5 | 90 | 0.12 | X 002498 | 18.5 | 50 | 0.42 | X 002505 |
| 22 | 120 | 0.09 | X 002555 | 22 | 60 | 0.36 | X 002506 |
| 30 | 160 | 0.07 | X 002556 | 30 | 80 | 0.26 | X 002508 |
| 37 | 200 | 0.05 | X 002557 | 37 | 90 | 0.24 | X 002509 |
| 45 | 240 | 0.044 | X 002558 | 45 | 120 | 0.18 | X 002566 |
| 55 | 280 | 0.038 | X 002559 | 55 | 150 | 0.15 | X 002567 |
| 75 | 360 | 0.026 | X 002560 | 75 | 200 | 0.11 | X 002568 |
| 90 | 500 | 0.02 | X 010145 | 90/110 | 250 | 0.09 | X 002569 |
| 110 | 500 | 0.02 | X 010145 | 132/160 | 330 | 0.06 | X 002570 |
| | | | | 185 | 490 | 0.04 | X 002690 |
| | | | | 220 | | | |
| | | | | 300 | | | |

DC Reactor

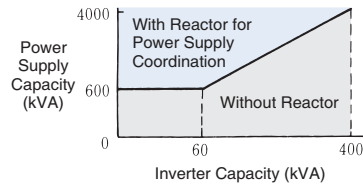
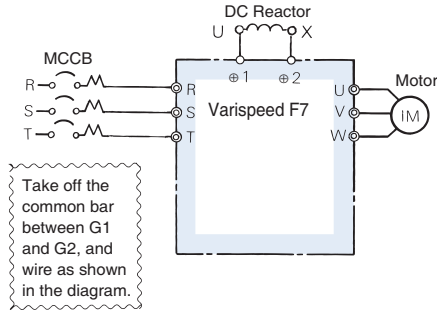

| 200 V Class | | | | 400 V Class | | | |
|---------------------------------|-----------------|---------------|----------|---------------------------------|-----------------|---------------|----------|
| Max. Applicable Motor Output kW | Current Value A | Inductance mH | Code No. | Max. Applicable Motor Output kW | Current Value A | Inductance mH | Code No. |
| 0.4 | 5.4 | 8 | X010048 | 0.4 | 3.2 | 28 | X010052 |
| 0.75 | | | | 0.75 | | | |
| 1.5 | 18 | 3 | X010049 | 1.5 | 5.7 | 11 | X010053 |
| 2.2 | | | | 2.2 | | | |
| 3.7 | | | | 3.7 | | | |
| 5.5 | 36 | 1 | X010050 | 5.5 | 23 | 3.6 | X010055 |
| 7.5 | | | | 7.5 | | | |
| 11 | 72 | 0.5 | X010051 | 11 | 33 | 1.9 | X010056 |
| 15 | | | | 15 | | | |
| 18.5 | 90 | 0.4 | X010176 | 18.5 | 47 | 1.3 | X010177 |
| 22 to 110 | Built-in | | | 22 to 300 | Built-in | | |

Fuse installation

To protect the inverter, it is recommended to use semiconductor fuses like they are shown in the table below

| Inverter Type | FUSE | | |
|---------------|-------------|-------------|-------------------------------------|
| | Voltage (V) | Current (A) | I ² t (A ² s) |
| 20P4 | 240 | 10 | 12~25 |
| 20P7 | 240 | 10 | 12~25 |
| 21P5 | 240 | 15 | 23~55 |
| 22P2 | 240 | 20 | 34~98 |
| 23P7 | 240 | 30 | 82~220 |
| 25P5 | 240 | 40 | 220~610 |
| 27P5 | 240 | 60 | 290~1300 |
| 2011 | 240 | 80 | 450~5000 |
| 2015 | 240 | 100 | 1200~7200 |
| 2018 | 240 | 130 | 1800~7200 |
| 2022 | 240 | 150 | 870~16200 |
| 2030 | 240 | 180 | 1500~23000 |
| 2037 | 240 | 240 | 2100~19000 |
| 2045 | 240 | 300 | 2700~55000 |
| 2055 | 240 | 350 | 4000~55000 |
| 2075 | 240 | 450 | 7100~64000 |
| 2090 | 240 | 550 | 11000~64000 |
| 2110 | 240 | 600 | 13000~83000 |

| Inverter Type | FUSE | | |
|---------------|-------------|-------------|-------------------------------------|
| | Voltage (V) | Current (A) | I ² t (A ² s) |
| 40P4 | 480 | 5 | 6~55 |
| 40P7 | 480 | 5 | 6~55 |
| 41P5 | 480 | 10 | 10~55 |
| 42P2 | 480 | 10 | 18~55 |
| 43P7 | 480 | 15 | 34~72 |
| 44P0 | 480 | 20 | 50~570 |
| 45P5 | 480 | 25 | 100~570 |
| 47P5 | 480 | 30 | 100~640 |
| 4011 | 480 | 50 | 150~1300 |
| 4015 | 480 | 60 | 400~1800 |
| 4018 | 480 | 70 | 700~4100 |
| 4022 | 480 | 80 | 240~5800 |
| 4030 | 480 | 100 | 500~5800 |
| 4037 | 480 | 125 | 750~5800 |
| 4045 | 480 | 150 | 920~13000 |
| 4055 | 480 | 150 | 1500~13000 |
| 4075 | 480 | 250 | 3000~55000 |
| 4090 | 480 | 300 | 3800~55000 |
| 4110 | 480 | 350 | 5400~23000 |
| 4132 | 480 | 400 | 7900~64000 |
| 4160 | 480 | 450 | 14000~250000 |
| 4185 | 480 | 600 | 20000~250000 |
| 4220 | 480 | 700 | 34000~400000 |
| 4300 | 480 | 900 | 52000~920000 |

ALL DIMENSIONS SHOWN ARE IN MILLIMETERS.
To convert millimeters into inches, multiply by 0.03937. To convert grams into ounces, multiply by 0.03527.