



# PNOZ® Safety Relays

**pilz**

more than automation  
safe automation

Safety relays and modular safety systems  
for monitoring plant and machinery

The optimum safety solution for every requirement.



# ▶ PNOZ® safety relays guarantee economy and s

<b>Control and monitoring technology</b> (Electrical safety to IEC 60 204-1)	<b>Electronic monitoring relays</b>			S-Range	Voltage Phase sequence Current Earth fault True power Thermistor Standstill/fault voltage monitoring	<b>Enq. no.*</b> 4
<b>Command and signal</b>	<b>E-STOP pushbutton</b>			PIT ES		5
<b>Sensor technology</b>	<b>Safety switches</b>		Non-contact safety switch	PSEN		6
<b>Safe control technology</b> (Functional safety to EN 954-1)	<b>Safety relays</b>		Compact	PNOZclassic PNOZ X PNOZelog	◆ ◆ ◆ ◆ ◆ ◆	7
			Modular	PNOZmulti PNOZpower PNOZplus	◆ ◆ ◆ ◆ ◆ ◆	8
			Software			8
	<b>Programmable safety systems</b>		Safety systems	PSS	◆ ◆ ◆ ◆ ◆ ◆	9
			Software			9
	<b>Safe bus systems</b>		Safety systems	SafetyBUS p	◆ ◆ ◆ ◆ ◆ ◆	10
Software					10	
<b>Operating and monitoring</b> (operator terminals)	<b>Text displays</b>			PX		11
	<b>Line-based operator terminals</b>			PXT		11
	<b>Graphics touchscreen terminals</b>			PMI		11
	<b>Software</b>					11
<b>Services</b> (Concepts and solutions)	<b>Consulting</b>		Safety advice Risk analysis Safety concepts Safety check			2
	<b>Engineering</b>		System supplier and project management Application support Service			2
			Technical Support Training and education, etc.			2 +
						3

# security of investment

## It pays to use safety technology

The protection of man and machine through the targeted control of hazardous movements, immense cost savings thanks to fewer accidents, reduced downtimes and fewer production losses – these are real benefits that you can enjoy when you use safe control technology from Pilz.

The PNOZ-range of safety relays is one of the cornerstones of safe automation at Pilz. It was back in 1987 that Pilz developed a product to protect both man and machine: the first emergency stop relay PNOZ – the synonym for safety relays. Other applications followed, and the combination of technical expertise and innovative ideas produced safety relays to cover all technical safety requirements economically. In addition to the classic E-STOP function, Pilz can now supply units to monitor safety gates, light barriers, two-hand controls, pressure mats, muting functions and much more.

## Contents

PNOZ safety relays guarantee economy and security of investment .....	2
PNOZ safety relays – The standard in safe control technology .....	4
PNOZ product range – The optimum safety solution for each application .....	6
PNOZelog electronic safety relays – Solid-state safety .....	8
PNOZelog – Technical details .....	12
PNOZ X safety relays – Customised safety for each application .....	16
PNOZ X – Technical details .....	19
PNOZpower modular safety system – Switching high loads safely .....	24
PNOZpower – Technical details .....	27
PNOZmulti modular safety system – Many functions – one solution .....	30
PNOZmulti – Technical details .....	32
Safety technology made simple .....	34
S-Range electronic monitoring relays – Taking control of every situation .....	36
Safety technology – Further information .....	38
Request for information and consultation .....	39

*Controlling plant and machinery safely and economically.*



# ▶ PNOZ<sup>®</sup> safety relays – The standard in safe control

## Economical safety is our strength

Pilz offers a universal concept for safety solutions that can be applied right across industry. For simple applications, safety relays from the PNOZ X and PNOZelog-ranges are

guaranteed to be cost-effective. For safety applications of medium complexity, the modular safety system PNOZmulti is the most economical solution. The PNOZmulti covers the area between 4 and 14 safety functions perfectly, i.e. if you have more than 4 safety

functions to perform, the PNOZmulti is the most economical solution. On more complex or distributed plants, PSS-range programmable safety systems and the safe, open bus system SafetyBUS p can be used.

*Pilz offers a universal concept for safety-related solutions.*

**Economy/costs**

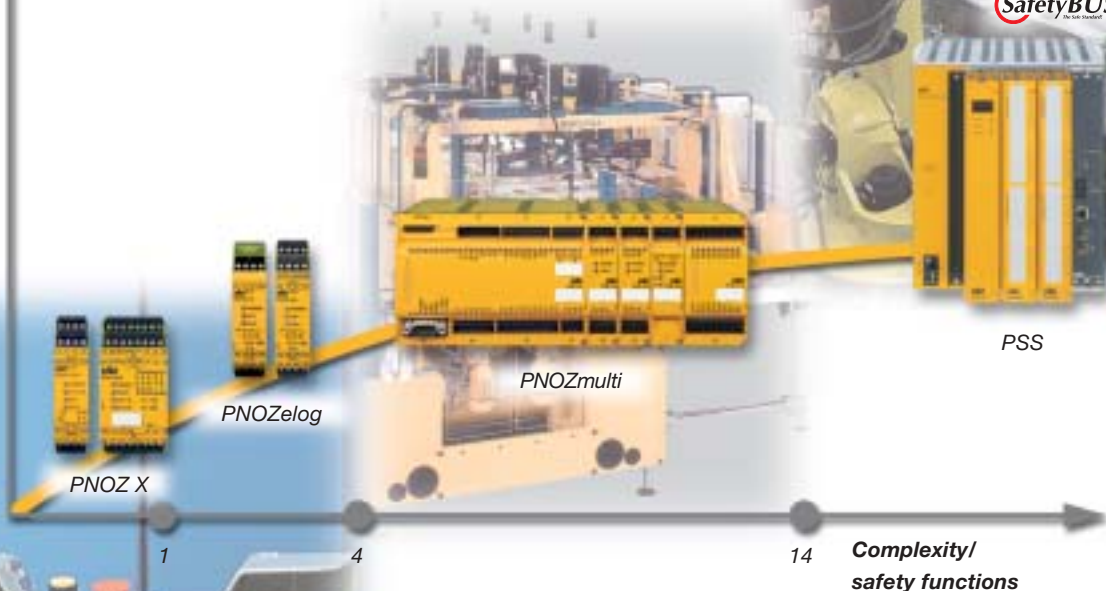

**SafetyBUS p**

PSS

PNOZmulti

PNOZelog

PNOZ X

1

4

14

# Control technology

## PNOZ safety relays – Certified worldwide

When using PNOZ safety relays, the aim is to keep the risk to man and machine as low as possible. Internationally coordinated statutory instruments have been introduced to ensure that the same level of protection is guaranteed in all countries. Our safety relays comply with these international standards and regulations. The PNOZ safety relay has been approved by BG and many other notified bodies and offers users considerable benefits. Long service life and high availability ensure it is cost-effective to use.

Save yourself the laborious process of wiring contactors when constructing your safety-related circuit – and still enjoy maximum safety, up to and including category 4 in accordance with EN 954-1.

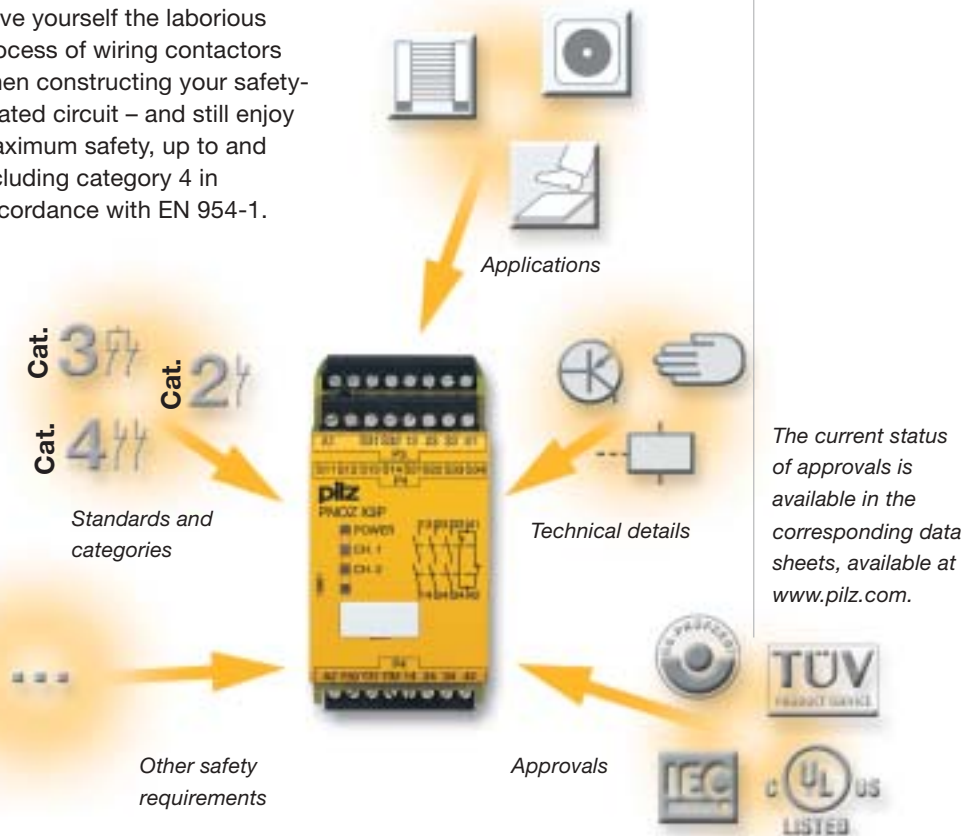

The current status of approvals is available in the corresponding data sheets, available at [www.pilz.com](http://www.pilz.com).

### Safety assessment in accordance with EN 954-1

#### S. Severity of injury

- S1 Slight (normally reversible) injury (i.e. cut or bruise)
- S2 Serious (normally irreversible) injury

#### F. Frequency and/or exposure time to hazard

- F1 Seldom to quite often
- F2 Frequent to continuous

### P. Possibility of avoiding the hazard

(generally related to the speed and frequency with which the hazardous part moves and to the distance from the hazardous part)

- P1 Possible under specific conditions
- P2 Scarcely possible

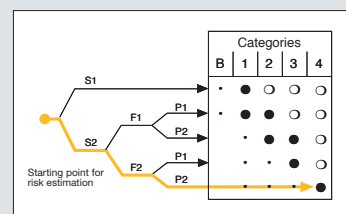

Example risk assessment.

### Safety assessment in accordance with EN 954-1

According to the standard EN 954-1, safety-related requirements in control technology can be divided into five categories, graded according to the “severity of injury”, “exposure time to the hazard” and the “possibility of avoiding the hazard”.

The standard EN 954-1 is currently being revised by ISO and is expected to be published at the end of 2003 as DIN EN ISO 13894-1. Details will be available from 2004 at [www.pilz.com](http://www.pilz.com).



# ▶ PNOZ® product ranges – The optimum safety solution

## More than automation – safe automation

For us, safety is more than just a product. Safe control technology is based on experience and

innovation. We have constantly expanded our product range in consultation with our customers. Based on their different features and functionalities, our safety relays can be divided into the

following product ranges – in other words, Pilz provides the optimum safety solution for each application.

### PNOZclassic

- ▶ The original PNOZ



### PNOZ X

- ▶ Customised safety for each function
- ▶ Electromechanical, volt-free
- ▶ AC/DC versions



**PNOZ®**



### PNOZelog

- ▶ Linkable
- ▶ Non-wearing
- ▶ Extended diagnostics



### PNOZpower

- ▶ High loads from 8 A to 16 A
- ▶ Switch motor loads safely
- ▶ Modular output contacts



### PNOZmulti

- ▶ Freely configurable
- ▶ Multifunctional
- ▶ Modular safety system

# solution for each application

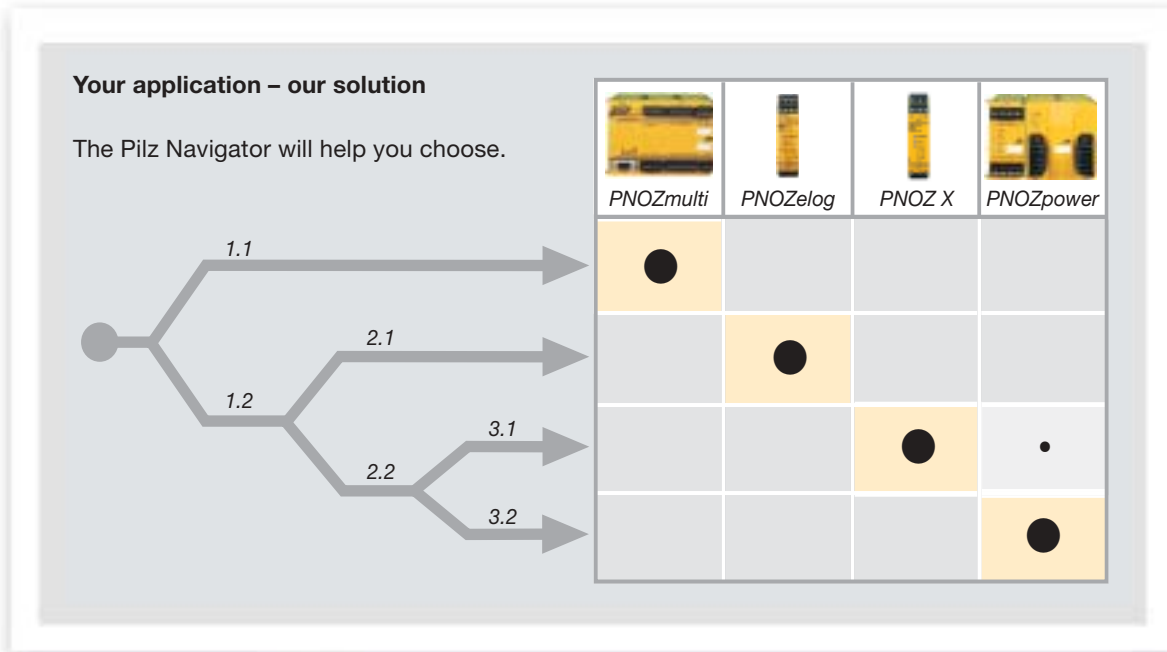

*PNOZ safety relays – always the right solution!*

## 1. Number of safety functions

- 1.1 You require four or more safety functions, which you wish to cover in your application. It does not matter whether the safety functions you need to cover are identical or different.
- 1.2 You require less than 4 safety functions.

## 2. Outputs that can be linked logically versus volt-free outputs

- 2.1 Outputs that can be linked are particularly useful in your application because logic AND/OR connections enable you to connect as many units as necessary in series and you also save the additional wiring at the output.
- 2.2 You require volt-free outputs for your application / you need to switch AC loads.

## 3. Compact safety relays versus modular output contacts

- 3.1 Compact safety relays are more appropriate for your application if you only need to cover a limited number of safety functions.
- 3.2 Modular output contacts can be adapted flexibly to your requirements. If necessary it is easy to expand the number of contacts required. So you only pay for what you actually need and you reduce your costs.



## ► PNOZelog electronic safety relays – Solid-state s

### **Linkable, maintenance-free and long-lasting**

The innovative PNOZelog product range, electronics-based and in a compact design, combines the classic, electromechanical PNOZ safety relay with the benefits of modern electronics. Wear-resistance, safety, long service life and high availability ensure it is cost-effective to use. What's more, the PNOZelog can be linked through logic AND/OR operations. The reduction in the amount of wiring involved is a huge advantage.

The PNOZelog product range is designed in accordance with failsafe technology to category 4 of EN 954-1. Power-up tests, self-checking and runtime tests guarantee maximum safety. Electronic safety relays are ideally suitable for frequent switching of small and medium-sized loads.

PNOZelog uses semiconductor technology and is therefore resistant to shock and vibration, making it suitable for use on mobile applications where there is a lot of vibration, for example. The use of modern electronics ensures the units are durable and maintenance-free.

*Example: using PNOZelog safety relays on a packaging machine.*

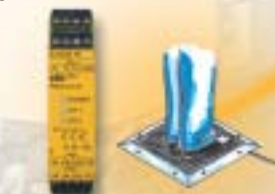
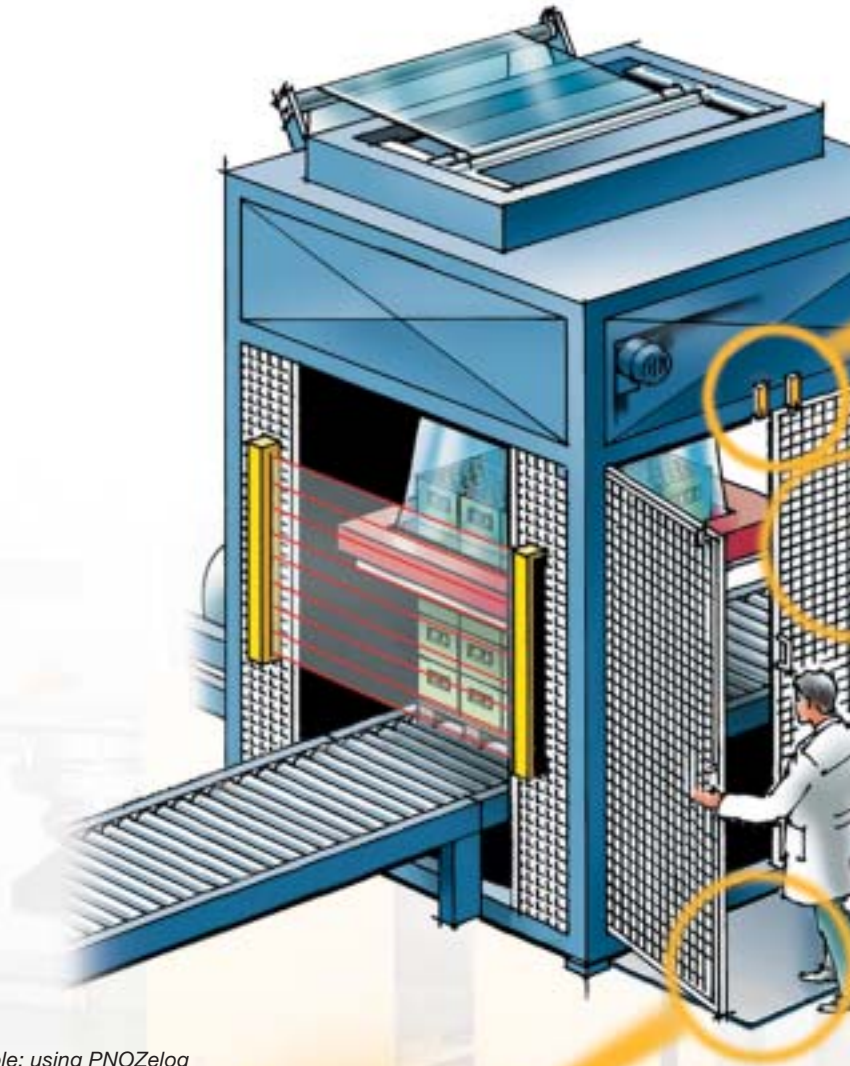

PNOZ e4.1p

safety



**Your benefits at a glance**

- ▶ Logic function links (AND/OR) mean less wiring.
- ▶ Continuous function test on the outputs. This increases safety even on functions that are seldom used, e.g. E-STOP.
- ▶ Continuous self-checks provide the highest level of safety. Fault detection is not interconnected with the switch on/off cycle.
- ▶ Consistent use of semiconductor technology means no maintenance is necessary. No malfunction due to contact welding, contamination, bounce or burning.
- ▶ Long service life, even with frequent operations or cyclical functions.
- ▶ Safe switching operations even on the smallest of loads.
- ▶ Safe switching even on mobile applications.



# ▶ PNOZelog electronic safety relays

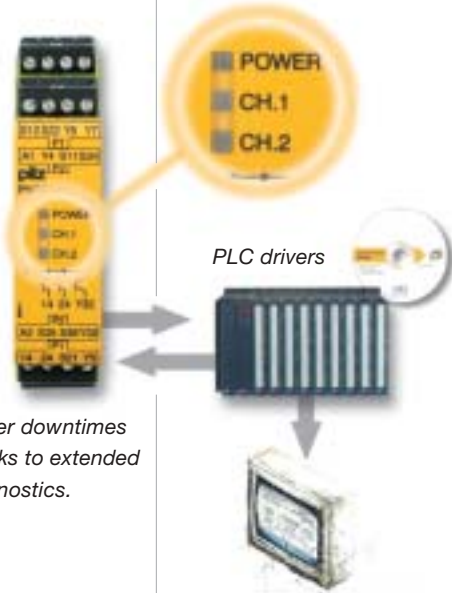

Fewer downtimes thanks to extended diagnostics.

## Easy-to-use diagnostics make the units cost-effective

PNOZelog has extensive diagnostic options. Firstly, via the simple LED display and status output, which enable the easiest possible on-site diagnostics, without additional tools. Secondly, via an integral diagnostic interface to the PLC. If several PNOZelog units are used, all you need is one PLC output and one PLC input for each unit that you use. Drivers are available for all common PLC systems. The detailed information that is gained about the products' system status reduces machine downtimes and enables any potential error sources to be removed immediately.

## Complete safety functions through logic function links

Units in the PNOZelog product range can be linked via logic operations to form complete safety functions. AND/OR operations are both available. The use of logic functions means that the output requires no additional wiring. Both

outputs on the PNOZelog units are freely available. As many units as necessary can be connected in series, removing the need for additional devices.

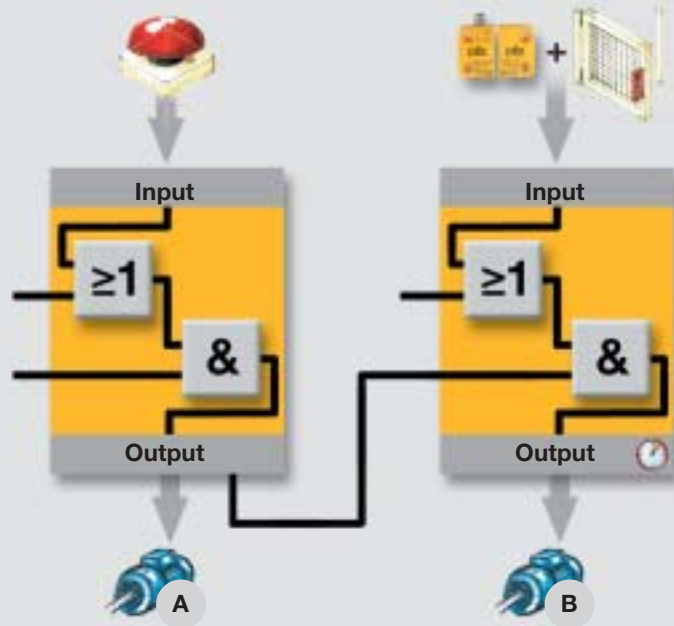

Less wiring because outputs can be linked.



If the E-STOP is operated, motor A is switched off immediately AND motor B is switched off with a time delay.



If the safety gate is opened, only motor B is switched off, with a time delay.

**“2 in 1” – The bifunctional PNOZelog**

Bifunctional PNOZelog safety relays form an extremely compact safety unit. It is possible to cover two safety functions simultaneously with just one unit. The safety functions are already “AND”-linked internally. Each safety function comes with a separate signal output. You save on wiring, because you only need one unit for two safety functions. With a width of just 22.5 mm, the space requirement in the control cabinet is reduced to a minimum, while maximum functionality is maintained.

At the moment, the PNOZ e5.11p and PNOZ e5.13p are available for E-STOP/safety gate or safety gate/safety gate monitoring. For further information please refer to the technical details.

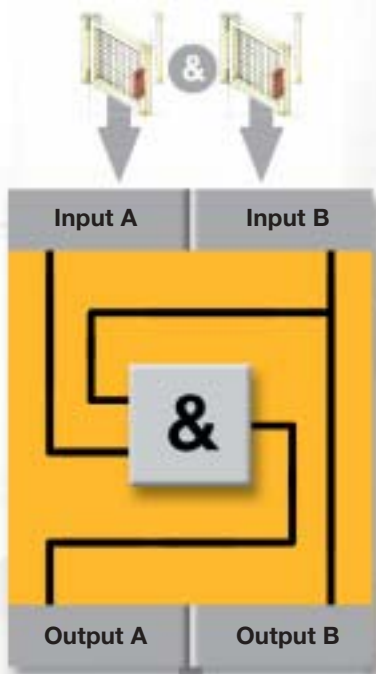

*Thanks to an internal AND connection, two safety functions can be covered simultaneously – with just one unit!*

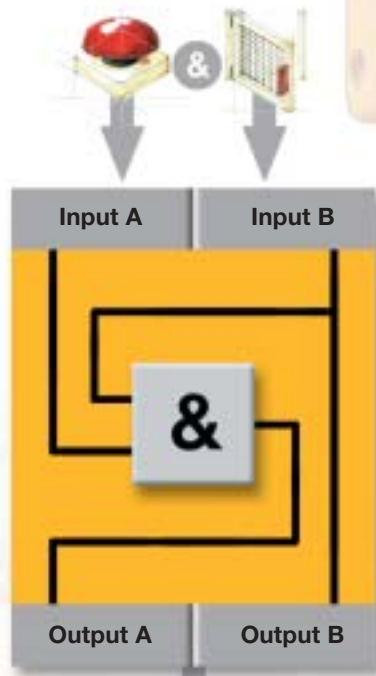

*A bifunctional PNOZelog – minimum space, maximum functionality.*



## ► PNOZelog – Technical details

### PNOZelog – Compact, electronic safety relays



#### **PNOZ e1p**

Emergency stop relay and safety gate monitor in accordance with EN 60204-1 (VDE 0113-1), 12/97 and IEC 60 204-1, 10/97

#### Order numbers:

- 774 130 – 24 VDC, plug-in terminals with screw connection
- 784 130 – 24 VDC, plug-in terminals with cage clamp connection

#### Accessories:

- 874 130...<sup>1)</sup> – PLC drivers for PNOZelog, for reading the diagnostic data

- Applications in accordance with EN 954-1, 07/96, category 2, 3 or 4
- Monitored or automatic reset can be selected
- Auxiliary output can be switched to a diagnostic output
- Monitoring of shorts across contacts can be selected
- Continuous self monitoring
- Supply voltage: 24 VDC
- Outputs: semiconductor technology, 2 safety outputs and 1 auxiliary output
- Switching capability: DC1: 24 V/2 A
- Dimensions (H x W x D): 87 x 22.5 x 121 mm



#### **PNOZ e1.1p**

Emergency stop relay and safety gate monitor in accordance with EN 60204-1 (VDE 0113-1), 12/97 and IEC 60204-1, 10/97

#### Order numbers:

- 774 133 – 24 VDC, plug-in terminals with screw connection
- 784 133 – 24 VDC, plug-in terminals with cage clamp connection

#### Accessories:

- 874 130...<sup>1)</sup> – PLC drivers for PNOZelog, for reading the diagnostic data

- Applications in accordance with EN 954-1, 07/96, category 2, 3 or 4
- Monitored or automatic reset can be selected
- Auxiliary output can be switched to a diagnostic output
- One AND and one OR input to AND/OR link several PNOZelog units
- Monitoring of shorts across contacts can be selected
- Continuous self monitoring
- Supply voltage: 24 VDC
- Outputs: semiconductor technology, 2 safety outputs and 1 auxiliary output
- Switching capability: DC1: 24 V/2 A
- Dimensions (H x W x D): 87 x 22.5 x 121 mm



#### **PNOZ e1vp**

Emergency stop relay and safety gate monitor in accordance with EN 60204-1 (VDE 0113-1), 12/97 and IEC 60204-1, 10/97

#### Order numbers:

- 774 131 – 10 s, 24 VDC, plug-in terminals with screw connection
- 784 131 – 10 s, 24 VDC, plug-in terminals with cage clamp connection
- 774 132 – 300 s, 24 VDC, plug-in terminals with screw connection
- 784 132 – 300 s, 24 VDC, plug-in terminals with cage clamp connection

#### Accessories:

- 874 130...<sup>1)</sup> – PLC drivers for PNOZelog, for reading the diagnostic data

- Applications in accordance with EN 954-1, 07/96, category 2, 3 or 4
- Monitored or automatic reset can be selected
- Delay time can be set
- Auxiliary output can be switched to a diagnostic output
- One AND and one OR input to AND/OR link several PNOZelog units
- Monitoring of shorts across contacts can be selected
- Continuous self monitoring
- Supply voltage: 24 VDC
- Outputs: semiconductor technology, 2 safety outputs delayed/instantaneous, 1 auxiliary output
- Switching capability: DC1: 24 V/2 A
- Dimensions (H x W x D): 87 x 22.5 x 121 mm



## PNOZelog – Compact, electronic safety relays



### PNOZ e2.1p/PNOZ e2.2p

Two-hand control devices in accordance with EN 574

Order numbers:  
PNOZ e2.1p

- ▶ 774 136 – 24 VDC, plug-in terminals with screw connection
- ▶ 784 136 – 24 VDC, plug-in terminals with cage clamp connection

PNOZ e2.2p

- ▶ 774 135 – 24 VDC, plug-in terminals with screw connection
- ▶ 784 135 – 24 VDC, plug-in terminals with cage clamp connection

- ▶ PNOZ e2.1p:  
Conforms to EN 574, 11/96 Type III C
- ▶ PNOZ e2.2p:  
Conforms to Type III A of EN 574, 02/97
- ▶ Auxiliary output can be switched to a diagnostic output
- ▶ AND and OR input to link several PNOZelog units logically
- ▶ Monitoring of shorts across contacts via 2 test pulse outputs
- ▶ Status display
- ▶ Feedback loop for monitoring external contactors
- ▶ Supply voltage: 24 VDC
- ▶ Outputs: semiconductor technology, 2 safety outputs, 1 auxiliary output
- ▶ Switching capability: DC1: 24 V/2 A
- ▶ Dimensions (H x W x D): 87 x 22.5 x 121 mm



### PNOZ e3.1p

Safety gate monitor in accordance with EN 60204-1 (VDE 0113-1), 12/97 and IEC 60204-1, 10/97

Order numbers:

- ▶ 774 139 – 24 VDC, plug-in terminals with screw connection
- ▶ 784 139 – 24 VDC, plug-in terminals with cage clamp connection

Accessories:

- ▶ 874 130...<sup>1)</sup> – PLC drivers for PNOZelog, for reading the diagnostic data

- ▶ Application range in accordance with EN 954-1, 07/96, category 2, 3 or 4: safety gate monitoring
- ▶ Evaluation device for safety sensors PSEN 2.1p-10 and PSEN 2.1p-11 and for position switches
- ▶ Monitored or automatic reset can be selected
- ▶ Auxiliary output can be switched to a diagnostic output
- ▶ One AND and one OR input to AND/OR link several PNOZelog units
- ▶ Monitoring of shorts across contacts can be selected
- ▶ Continuous self monitoring
- ▶ Supply voltage: 24 VDC
- ▶ Outputs: semiconductor technology, 2 safety outputs, 1 auxiliary output
- ▶ Switching capability: DC1: 24 V/2 A
- ▶ Dimensions (H x W x D): 87 x 22.5 x 121 mm

... <sup>1)</sup> When ordering: please state the type of licence you require after the order number (..B for basic licence, ..K for copy licence, ..G for general licence, ..U for update licence), e.g. 874 130B.





## ► PNOZelog – Technical details

### PNOZelog – Compact, electronic safety relays



#### PNOZ e3vp

Safety gate monitor in accordance with EN 60 204-1 (VDE 0113-1), 12/97 and IEC 60 204-1, 10/97

#### Order numbers:

- ▶ 774 137 – 10 s, 24 VDC, plug-in terminals with screw connection
- ▶ 784 137 – 10 s, 24 VDC, plug-in terminals with cage clamp connection
- ▶ 774 138 – 300 s, 24 VDC, plug-in terminals with screw connection
- ▶ 784 138 – 300 s, 24 VDC, plug-in terminals with cage clamp connection

#### Accessories:

- ▶ 874 130...<sup>1)</sup> – PLC drivers for PNOZelog, for reading the diagnostic data

- ▶ Application range in accordance with EN 954-1, 07/96, category 2, 3 or 4: safety gate monitoring
- ▶ Evaluation device for safety sensors PSEN 2.1p-10 and PSEN 2.1p-11 and for position switches
- ▶ Monitored or automatic reset can be selected
- ▶ Delay time can be set
- ▶ Auxiliary output can be switched to a diagnostic output
- ▶ One AND and one OR input to AND/OR link several PNOZelog units
- ▶ Monitoring of shorts across contacts can be selected
- ▶ Continuous self monitoring
- ▶ Supply voltage: 24 VDC
- ▶ Outputs: semiconductor technology, 2 safety outputs delayed/instantaneous, 1 auxiliary output
- ▶ Switching capability: DC1: 24 V/2 A
- ▶ Dimensions (H x W x D): 87 x 22.5 x 121 mm



#### PNOZ e4.1p

Evaluation device for safety mats in accordance with EN 1760-1 and DIN EN ISO 13 856-1, 08/01

#### Order numbers:

- ▶ 774 180 – 24 VDC, plug-in terminals with screw connection
- ▶ 784 180 – 24 VDC, plug-in terminals with cage clamp connection

- ▶ Application range in accordance with EN 954-1, 07/96, category 3
- ▶ For connecting Mayser safety mats  
Type: SM/BK
- ▶ Suitable as an evaluation device for connection to PSS/SafetyBUS p/PNOZmulti
- ▶ Auxiliary output can be switched to a diagnostic output
- ▶ One AND and one OR input to AND/OR link several PNOZelog units
- ▶ Continuous self monitoring
- ▶ With or without reset function
- ▶ Supply voltage: 24 VDC
- ▶ Outputs: semiconductor technology, 2 safety outputs, 1 auxiliary output
- ▶ Switching capability: DC1: 24 V/2 A
- ▶ Dimensions (H x W x D): 87 x 22.5 x 121 mm



The current status of approvals is available in the corresponding documentation at [www.pilz.com](http://www.pilz.com).

## PNOZelog – Compact, electronic safety relays



### PNOZ e4vp

Evaluation device for safety mats in accordance with EN 1760-1 and DIN EN ISO 13856-1, 08/01

Order numbers:

- ▶ 774 181 – 24 VDC, 10 s, plug-in terminals with screw connection
- ▶ 784 181 – 24 VDC, 10 s, plug-in terminals with cage clamp connection

- ▶ Application range in accordance with EN 954-1, 07/96, category 3
- ▶ For connecting Mayser safety mats  
Type: SM/BK
- ▶ Suitable as an evaluation device for connection to PSS/SafetyBUS p/PNOZmulti
- ▶ Auxiliary output can be switched to a diagnostic output
- ▶ One AND and one OR input to AND/OR link several PNOZelog units
- ▶ Continuous self monitoring
- ▶ With or without reset function

- ▶ Supply voltage: 24 VDC
- ▶ Outputs: semiconductor technology, 2 safety outputs delayed/instantaneous, 1 auxiliary output
- ▶ Switching capability: DC1: 24 V/2 A
- ▶ Dimensions (H x W x D): 87 x 22.5 x 121 mm



### PNOZ e5.11p

Combined unit consisting of E-STOP relay and safety gate monitor in accordance with EN 60204-1 (VDE 0113-1), 12/97 and IEC 60204-1, 10/97, internal AND link

Order numbers:

- ▶ 774 190 – 24 VDC, plug-in terminals with screw connection
- ▶ 784 190 – 24 VDC, plug-in terminals with cage clamp connection

Accessories:

- ▶ 874 130...<sup>1)</sup> – PLC drivers for PNOZelog, for reading the diagnostic data

- ▶ Applications in accordance with EN 954-1, 07/96, category 2 or 3
- ▶ 2 safety functions in one unit, internal AND-link
- ▶ Monitored or automatic reset can be selected
- ▶ AND input to AND link several PNOZelog units
- ▶ Continuous self monitoring

- ▶ Supply voltage: 24 VDC
- ▶ Outputs: semiconductor technology, 2 safety outputs and 2 auxiliary outputs
- ▶ Switching capability: DC1: 24 V/2 A
- ▶ Dimensions (H x W x D): 87 x 22.5 x 121 mm



### PNOZ e5.13p

Combined unit consisting of E-STOP relay in accordance with EN 60204-1 (VDE 0113-1), 12/97 and IEC 60204-1, 10/97 and safety gate monitor in accordance with EN 60947-5-3, PDF-M internal AND-link

Order numbers:

- ▶ 774 191 – 24 VDC, plug-in terminals with screw connection
- ▶ 784 191 – 24 VDC, plug-in terminals with cage clamp connection

Accessories:

- ▶ 874 130...<sup>1)</sup> – PLC drivers for PNOZelog, for reading the diagnostic data

- ▶ Applications in accordance with EN 954-1, 07/96, category 2 or 3
- ▶ 2 safety functions in one unit, internal AND-link
- ▶ Evaluation device for safety sensor from the PSEN 2 series
- ▶ Monitored or automatic reset can be selected
- ▶ AND input to AND link several PNOZelog units
- ▶ Continuous self monitoring

- ▶ Supply voltage: 24 VDC
- ▶ Outputs: semiconductor technology, 2 safety outputs and 2 auxiliary outputs
- ▶ Switching capability: DC1: 24 V/2 A
- ▶ Dimensions (H x W x D): 87 x 22.5 x 121 mm



...<sup>1)</sup> When ordering: please state the type of licence you require after the order number (...B for basic licence, ...K for copy licence, ...G for general licence, ...U for update licence), e.g. 874 130B.



## ▶ PNOZ X safety relays – Customised safety for e

### **PNOZ X safety relays – Proven X-times over**

Safety relays from the PNOZ X product range are proven through their reliability and robustness and have developed a wide application range in the most varied of safety applications. PNOZ is the most widely used safety relay in the world.

Its technical features are based on voltage-free, electro-mechanical contacts in 2 or 3 relay technology. Sizes vary from 22.5 to 90 mm, the number of contacts ranges from 2 to 8. No matter what your safety requirement looks like – PNOZ X has already been proven a million times over in rugged everyday industrial environments – and will surely be the right solution for you too.

*Proven safety that you can trust!*

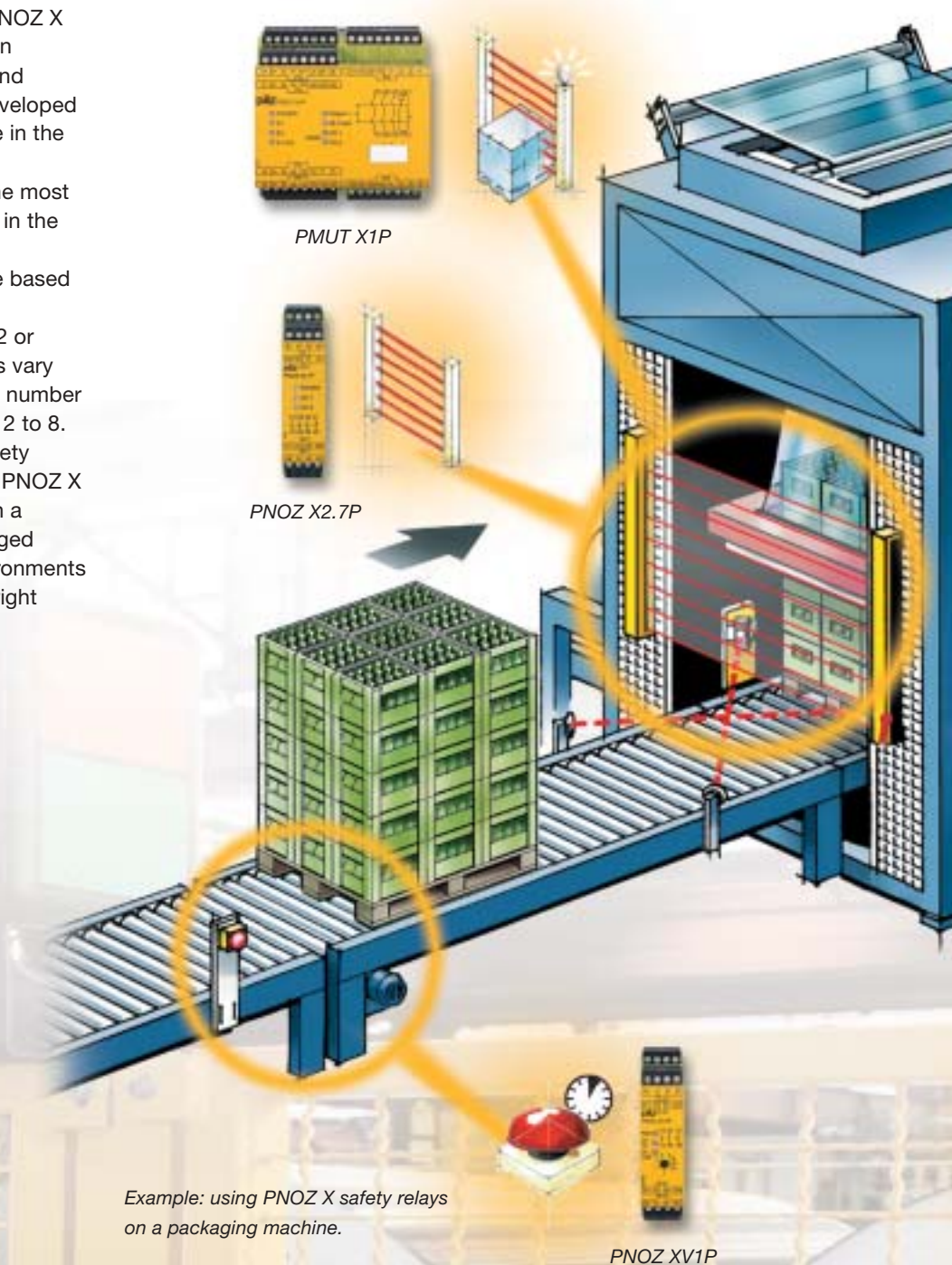

*Example: using PNOZ X safety relays on a packaging machine.*

*PNOZ XV1P*

# each application



PNOZ X2.8P

PNOZ X2P

P2HZ X4P

### Your benefits at a glance

- ▶ Can be used universally for all safety functions, such as monitoring E-STOPS, safety gates, light barriers and much more. Also available: delayed and instantaneous expander modules, safe timers, safe monitoring relays
- ▶ Units with plug-in terminals, ensuring faster commissioning
- ▶ Highest level of safety with the least space requirement
- ▶ Excellent price/performance ratio
- ▶ Low storage costs thanks to universal power supply



## ▶ PNOZ X safety relays



Switch over to lower storage costs.

### **PNOZ X safety relays – With universal power supply**

PNOZ X units are also available with a universal power supply. Different supply voltage versions, for example from ▶ 24 VAC/DC to 240 VAC/DC are available in a single unit. Voltage swings largely have no effect. “Unusual” operating voltages such as 110 VDC are also possible.

Monitor up to 4 muting sensors with the PMUT X1P.



### **A highlight from the PNOZ X product range – PMUT X1P for muting functions**

Muting is the safe, automatic and temporary suspension of an electro-sensitive protective device. Muting is frequently used to transport material into and out of a hazardous area. Muting sensors are used to detect this material safely. In the process, mainly light barriers or light curtains are temporarily suspended, while muting lamps signal their status. The PMUT X1P safety relay has inputs for all types of muting sensors, such as inductive initiators, proximity switches,



light barriers and mechanical switches. On the PMUT X1P, sensor technology can be connected directly, without using terminal blocks. It is possible to connect light curtains of any make, using contacts or semiconductor technology. The integral ability to switch muting lamps automatically

guarantees high availability and safety, because the PMUT X1P monitors the muting lamp. If a fault occurs, the unit automatically switches to a second lamp. The defective lamp can be exchanged during operation.

## ▶ PNOZ X – Technical details

### PNOZ X – Electromechanical, compact safety relays



#### PNOZ X2P

Emergency stop relay and safety gate monitor in accordance with VDE 0113-1, 11/98 and EN 60204-1, 12/97

Order numbers:

- ▶ 777 303 – PNOZ X2P: 24 VAC/DC, plug-in terminals with screw connection
- ▶ 777 307 – PNOZ X2P: 48 ... 240 VAC/DC, plug-in terminals with screw connection
- ▶ 787 303 – PNOZ X2P: 24 VAC/DC, plug-in terminals with cage clamp connection
- ▶ 787 307 – PNOZ X2P: 48 ... 240 VAC/DC, plug-in terminals with cage clamp connection
- ▶ 774 306 – PNOZ X2.1: 24 VDC, terminals with screw connection

- ▶ Category 4, EN 954-1
- ▶ Dual-channel operation with detection of shorts across contacts
- ▶ Supply voltage 48 ... 240 VAC/DC: input circuit galvanically isolated
- ▶ Monitored or automatic reset can be selected
- ▶ Supply voltage: 24 VAC/DC; 48 ... 240 VAC/DC
- ▶ Switching capability: DC1: 24 V/4 A
- ▶ Output contacts: 2 safety contacts (N/O)
- ▶ Dimensions (H x W x D): 94 x 22.5 x 121 mm



#### PNOZ X2.7P/PNOZ X2.8P

Emergency stop relay and safety gate monitor in accordance with VDE 0113-1, 11/98 and EN 60204-1, 12/97

Order numbers:

- ▶ 777 305 – PNOZ X2.7P: 24 VAC/DC, plug-in terminals with screw connection
- ▶ 787 305 – PNOZ X2.7P: 24 VAC/DC, plug-in terminals with cage clamp connection
- ▶ 777 301 – PNOZ X2.8P: 24 VAC/DC, plug-in terminals with screw connection
- ▶ 787 301 – PNOZ X2.8P: 24 VAC/DC, plug-in terminals with cage clamp connection

- ▶ Category 4, EN 954-1
- ▶ Dual-channel operation with or without detection of shorts across contacts
- ▶ PNOZ X2.7P: monitored reset button
- ▶ PNOZ X2.8P: automatic reset possible
- ▶ Supply voltage: 24 VAC/DC
- ▶ Switching capability: DC1: 24 V/0.01 ... 6A
- ▶ Output contacts: 3 safety contacts (N/O), 1 auxiliary contact (N/C)
- ▶ Dimensions (H x W x D): 94 x 22.5 x 121 mm



#### PNOZ X3P

Emergency stop relay and safety gate monitor in accordance with VDE 0113, 11/89, EN 60204-1, 12/97 and IEC 204-1, 11/98

Order numbers\*:

- ▶ 777 310 – PNOZ X3P: 24 VAC/DC, plug-in terminals with screw connection
- ▶ 777 313 – PNOZ X3P: 24 V ... 240 VAC/DC, plug-in terminals with screw connection
- ▶ 787 310 – PNOZ X3P: 24 VAC/DC, plug-in terminals with cage clamp connection
- ▶ 787 313 – PNOZ X3P: 24 VAC/DC, plug-in terminals with cage clamp connection
- ▶ 774 318 – PNOZ X3: 230 VAC/DC, plug-in terminals with screw connection

- ▶ Category 4, EN 954-1
- ▶ Monitored or automatic reset can be selected
- ▶ 1 semiconductor output (K1/K2)
- ▶ Supply voltage 24 VAC/DC; 24 V ... 240 VAC/DC: input circuit galvanically isolated
- ▶ Safety gate function with N/C / N/O combination
- ▶ Dual-channel operation with or without detection of shorts across contacts
- ▶ Supply voltage: 24 VAC/DC; 24 V ... 240 VAC/DC
- ▶ Switching capability: DC1: 24 V/8 A
- ▶ Output contacts: 3 safety contacts (N/O), 1 auxiliary contact (N/C)
- ▶ Dimensions (H x W x D): 94 x 45 x 122 mm



\*Others available on request.



## ► PNOZ X – Technical details

### PNOZ X – Electromechanical, compact safety relays



#### PNOZ X8P

Emergency stop relay and safety gate monitor in accordance with VDE 0113 part 1, 11/98, EN 60204-1, 12/97 and IEC 204-1, 11/98

Order numbers\*:

- ▶ 777 760 – 24 VDC, plug-in terminals with screw connection
- ▶ 777 768 – 230 VAC, plug-in terminals with screw connection
- ▶ 787 760 – 24 VDC, plug-in terminals with cage clamp connection
- ▶ 787 768 – 230 VAC, plug-in terminals with cage clamp connection

- ▶ Category 4, EN 954-1
- ▶ Dual-channel operation with or without detection of shorts across contacts
- ▶ Monitored or automatic reset can be selected
- ▶ Designed to be driven via semiconductor outputs
- ▶ 2 semiconductor outputs (Fault, K1/K2)
- ▶ Supply voltage: 24 VDC, others on request
- ▶ Switching capability: DC1: 24 V/8 A
- ▶ Output contacts: 3 safety contacts (N/O), 2 auxiliary contacts (N/C)
- ▶ Dimensions (H x W x D): 94 x 45 x 121 mm



#### PNOZ X9P

Emergency stop relay and safety gate monitor in accordance with VDE 0113 part 1, 11/98, EN 60204-1, 12/97 and IEC 204-1, 11/98

Order numbers:

- ▶ 777 609 – 24 VDC, plug-in terminals with screw connection
- ▶ 777 606 – 24 VDC, 100... 240 VAC, plug-in terminals with screw connection
- ▶ 787 609 – 24 VDC, plug-in terminals with cage clamp connection
- ▶ 787 606 – 24 VDC, 100... 240 VAC, plug-in terminals with cage clamp connection

- ▶ Category 4, EN 954-1
- ▶ Dual-channel operation with or without detection of shorts across contacts
- ▶ Monitored or automatic reset can be selected
- ▶ Designed to be driven via semiconductor outputs
- ▶ 2 semiconductor outputs (Fault, K1/K2)
- ▶ Supply voltage: 24 VDC, 100 ... 240 VAC
- ▶ Switching capability: DC1: 24 V/8 A
- ▶ Output contacts: 7 safety contacts (N/O), 2 auxiliary contacts (N/C)
- ▶ Dimensions (H x W x D): 94 x 90 x 121 mm



#### PNOZ XV1P

Emergency stop relay and safety gate monitor in accordance with VDE 0113 part 1, 11/98, EN 60204-1, 12/97 and IEC 204-1, 12/98

Order numbers:

- ▶ 777 601 – 3 s, 24 VDC, plug-in terminals with screw connection
- ▶ 777 602 – 30 s, 24 VDC, plug-in terminals with screw connection
- ▶ 787 601 – 3 s, 24 VDC, plug-in terminals with cage clamp connection
- ▶ 787 602 – 30 s, 24 VDC, plug-in terminals with cage clamp connection

- ▶ Category 4, EN 954-1
- ▶ Dual-channel operation with or without detection of shorts across contacts
- ▶ Monitored or automatic reset can be selected
- ▶ Supply voltage: 24 VDC
- ▶ Switching capability: DC1: 24 V/3 A
- ▶ Output contacts: 1 delayed safety contact (N/O); 2 instantaneous safety contacts (N/O)
- ▶ Dimensions (H x W x D): 94 x 22.5 x 121 mm

\*Others available on request.

## PNOZ X – Electromechanical, compact safety relays



### PNOZ XV3P

Emergency stop relay and safety gate monitor in accordance with VDE 0113 part 1, 11/98, EN 60204-1, 12/97 and IEC 204-1, 12/98

Order numbers\*:

- ▶ 777 512 – 3 s, 24 VDC, plug-in terminals with screw connection
- ▶ 777 510 – 30 s, 24 VDC, plug-in terminals with screw connection
- ▶ 787 512 – 3 s, 24 VDC, plug-in terminals with cage clamp connection
- ▶ 787 510 – 30 s, 24 VDC, plug-in terminals with cage clamp connection

- ▶ Category 4, EN 954-1
- ▶ Dual-channel operation with or without detection of shorts across contacts
- ▶ Monitored or automatic reset can be selected
- ▶ 2 delay-off safety contacts

- ▶ Supply voltage: 24 VDC
- ▶ Switching capability: DC1: 24 V/8 A
- ▶ Output contacts: 2 delayed safety contacts (N/O); 3 instantaneous safety contacts (N/O)
- ▶ Dimensions (H x W x D): 94 x 45 x 121 mm



### PNOZ XV3.1P

Emergency stop relay and safety gate monitor in accordance with VDE 0113 part 1, 11/98, EN 60204-1, 12/97 and IEC 60204-1, 10/97

Order numbers\*:

- ▶ 777 535 – 3 s fixed, 24 V ... 240 VAC/DC, plug-in terminals with screw connection
- ▶ 777 530 – 30 s selectable, 24 V ... 240 V AC/DC, plug-in terminals with screw connection
- ▶ 787 535 – 24 V ... 240 VAC/DC, plug-in terminals with cage clamp connection
- ▶ 787 530 – 24 V ... 240 VAC/DC, plug-in terminals with cage clamp connection

- ▶ Category 4, EN 954-1
- ▶ Dual-channel operation with or without detection of shorts across contacts
- ▶ Monitored or automatic reset can be selected
- ▶ 2 delay-off safety contacts
- ▶ Universal power supply 24 ... 240 VAC/DC
- ▶ Supply voltage: 24 VDC

- ▶ Supply voltage: 24 VDC; 24 V ... 240 VAC/DC
- ▶ Switching capability: DC1: 24 V/6 A
- ▶ Output contacts: 3 instantaneous safety contacts (N/O); 1 auxiliary contact (N/C); 2 delayed safety contacts (N/O)
- ▶ Dimensions (H x W x D): 94 x 90 x 121 mm

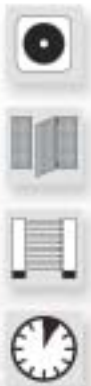

### P2HZ X1P

Two-hand control device in accordance with VDE 0113 part 1, 11/98, EN 60204-1, 12/97 and IEC 204-1, 11/98

Order numbers\*:

- ▶ 777 340 – 24 VDC, plug-in terminals with screw connection
- ▶ 787 340 – 24 VDC, plug-in terminals with cage clamp connection

- ▶ Conforms to type IIIC in accordance with EN 574 and category 4 in accordance with EN 954-1
- ▶ 2 semiconductor outputs (POWER, K1/K2)

- ▶ Supply voltage: 24 VDC, others on request
- ▶ Switching capability: DC1: 24 V/0.03 ... 4 A
- ▶ Output contacts: 3 safety contacts (N/O), 1 auxiliary contact (N/C)
- ▶ Dimensions (H x W x D): 94 x 45 x 122 mm



\*Others available on request.



## ► PNOZ X – Technical details

### PNOZ X – Electromechanical, compact safety relays



#### P2HZ X4P

Two-hand control device in accordance with VDE 0113, 11/98, EN 60204-1, 12/97 and IEC 204-1, 11/98

Order numbers:

- 777 355 – 24 VDC, plug-in terminals with screw connection
- 777 354 – 24 VAC, plug-in terminals with screw connection
- 787 355 – 24 VDC, plug-in terminals with cage clamp connection
- 787 354 – 24 VAC, plug-in terminals with cage clamp connection

- Conforms to type IIIC in accordance with EN 574 and category 4 in accordance with EN 954-1

- Supply voltage: 24 VAC/DC
- Switching capability: DC1: 24 V/4 A
- Output contacts: 3 safety contacts (N/O), 1 auxiliary contact (N/C)
- Dimensions (H x W x D): 94 x 22.5 x 121 mm



#### PZE X4P

Contact expander module in accordance with VDE 0113-1, 11/98, EN 60204-1, 12/97 and IEC 204-1, 11/98, to increase the number of safety contacts available

Order numbers:

- 777 585 – 24 VDC, plug-in terminals with screw connection
- 787 585 – 24 VDC, plug-in terminals with cage clamp connection

- Up to category 4, EN 954-1, depending on base unit
- Single-channel operation

- Supply voltage: 24 VDC
- Switching capability: DC1: 24 V/4 A
- Output contacts: 4 safety contacts (N/O)
- Dimensions (H x W x D): 94 x 22.5 x 121 mm



#### PZE 9P

Contact expander module in accordance with VDE 0113-1, 11/98, EN 60204-1, 12/97 and IEC 204-1, 11/98, to increase the number of safety contacts available

Order numbers:

- 777 140 – 24 VDC, plug-in terminals with screw connection
- 777 148 – 100 ... 240 VAC/DC, plug-in terminals with screw connection
- 787 140 – 24 VDC, plug-in terminals with cage clamp connection
- 787 148 – 100 ... 240 VAC/DC, plug-in terminals with cage clamp connection

- Up to category 4, EN 954-1, depending on base unit
- Diverse structure
- Dual-channel operation with the ability to detect shorts across contacts

- Supply voltage: 24 VAC/DC, 100 ... 240 VAC/DC
- Switching capability: DC1: 24 V/8 A
- Output contacts: 8 safety contacts (N/O), 1 auxiliary contact (N/C)
- Dimensions (H x W x D): 87 x 90 x 121 mm

## PNOZ X – Electromechanical, compact safety relays



### PMUT X1P

Unit for the temporary suspension of safety functions (muting) in accordance with EN 61 496-1

Order numbers:

- ▶ 778 010 – 24 VDC, plug-in terminals with screw connection
- ▶ 788 010 – 24 VDC, plug-in terminals with cage clamp connection

- ▶ Category 4, EN 954-1
- ▶ Up to 4 muting sensors
- ▶ Monitors and switches the muting lamps
- ▶ Parallel and serial muting
- ▶ Simultaneity monitoring
- ▶ 5 semiconductor outputs
- ▶ LED status indicators
- ▶ Supply voltage: 24 VDC
- ▶ Switching capability: DC1: 24 V/8 A
- ▶ Output contacts: 3 safety contacts (N/O), 1 auxiliary contact (N/C)
- ▶ Dimensions (H x W x D): 87 x 90 x 121 mm



### PNOZ X1

Emergency stop relay and safety gate monitor in accordance with VDE 0113-1, 11/98, EN 60204-1, 12/97 and IEC 204-1, 11/98

Order number:

- ▶ 774 300 – 24 VAC/DC, terminals with screw connection

- ▶ Category 2, EN 954-1
- ▶ Single-channel operation
- ▶ 3 N/O and 1 N/C with 22.5 mm width
- ▶ Supply voltage: 24 VAC/DC
- ▶ Switching capability: DC1: 24 V/4 A
- ▶ Output contacts: 3 safety contacts (N/O), 1 auxiliary contact (N/C)
- ▶ Dimensions (H x W x D): 87 x 22.5 x 122 mm



### PNOZ X4

Emergency stop relay and safety gate monitor in accordance with VDE 0113-1, 11/98, EN 60204-1, 12/97 and IEC 204-1, 11/98

Order number\*:

- ▶ 774 730 – 24 VDC, terminals with screw connection

- ▶ Category 4, EN 954-1
- ▶ Manual, monitored or automatic reset can be selected
- ▶ Single or dual-channel operation, with or without detection of shorts across contacts
- ▶ Supply voltage: 24 VDC, others on request
- ▶ Switching capability: DC1: 24 V/8 A
- ▶ Output contacts: 3 safety contacts (N/O), 1 auxiliary contact (N/C)
- ▶ Dimensions (H x W x D): 87 x 45 x 121 mm



### PNOZ X7

Emergency stop relay in accordance with VDE 0113 part 1, 11/98, EN 60204-1, 12/97 and IEC 204-1, 11/98

Order number\*:

- ▶ 774 059 – 24 VDC, terminals with screw connection

- ▶ Category 2, EN 954-1
- ▶ Single-channel operation
- ▶ Supply voltage: 24 VAC/DC, others on request
- ▶ Switching capability: DC1: 24 V/6 A
- ▶ Output contacts: 2 safety contacts (N/O)
- ▶ Dimensions (H x W x D): 87 x 22.5 x 122 mm

\*Others available on request.

The current status of approvals is available in the corresponding documentation at [www.pilz.com](http://www.pilz.com).



## ► PNOZpower modular safety system – Switching

Save costs through modular output contacts.

### Switching up to 16 A – no problem

The modular PNOZpower safety system is designed for monitoring E-STOPS, safety gates and light barriers. PNOZpower can switch currents of up to 16 A AC/DC per contact. An overall breaking capacity of 40 A is available per module. In each case, external contactors and contactor combinations are no longer required. The base module processes the inputs; the output modules are specifically matched to the respective load. The number and capacity of the required safety contacts can be scaled, depending on the application. A maximum of 4 modules can be connected to the base unit. Modules are wired to the base unit via an internal bus system.

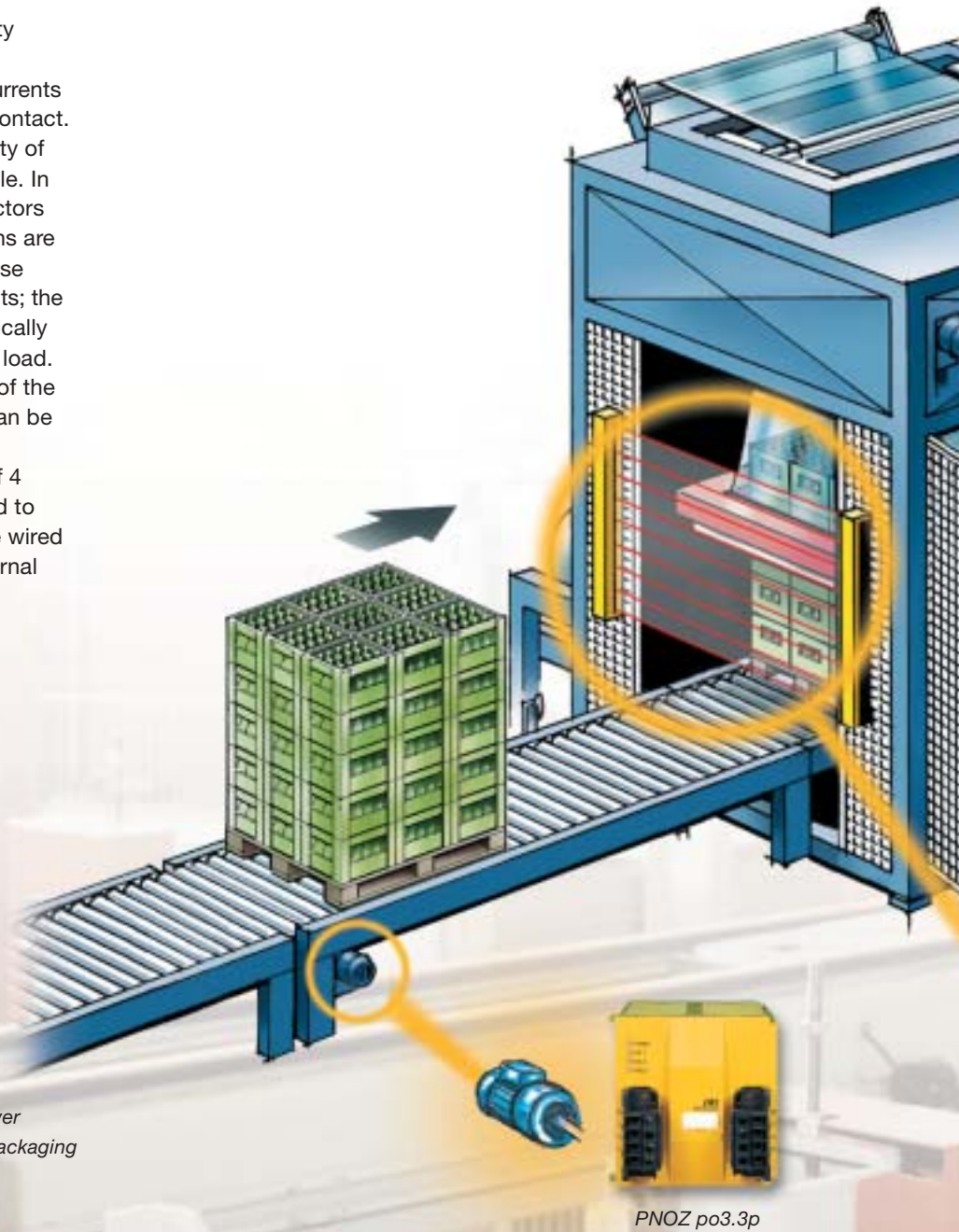

*Example: using the PNOZpower modular safety system on a packaging machine.*

PNOZ po3.3p

# ng high loads safely

## Your benefits at a glance

- ▶ The removal of external contactor combinations plus their wiring saves costs, space and commissioning time
- ▶ Diagnostics via LED: operating and fault status can be scanned on each module, resulting in fewer downtimes
- ▶ Plug-in connection terminals: pre-wired and easy to exchange if there is a fault
- ▶ Redundant load switching
- ▶ Scalable and flexible through selection of appropriate modules. You only pay for the functions that you actually use



PNOZ p1p PNOZ po3.1p PNOZ po3.2p



## ▶ PNOZpower modular safety system

*The optimum solution for each application: base units and expander modules can be freely combined.*

### Scalable output contacts with the PNOZ p1p base unit

In conjunction with at least one expander module, the base unit PNOZ p1p monitors E-STOPS, safety gates and light barriers. The expander modules shut down valves and motors safely and signal diagnostic data to a standard PLC.



Max. 4 expander modules, max. 32 output contacts



### With time delay – The PNOZ p1vp base unit

In addition to the functionality of the PNOZ p1p base unit, the PNOZ p1vp also has delayed output contacts.

Max. 4 instantaneous expander modules, max. 32 output contacts

Max. 4 delayed expander modules, max. 32 output contacts

### Volt-free switching with the PNOZ pe1p control module

In conjunction with at least one expander module, the PNOZ pe1p control module safely shuts down motors or supply voltages on valves and contactors. The PNOZ pe1p can be driven via:

- ▶ PSS-range programmable safety systems
- ▶ The safe bus system SafetyBUS p
- ▶ Safety relays PNOZelog, PNOZmulti and PNOZ X

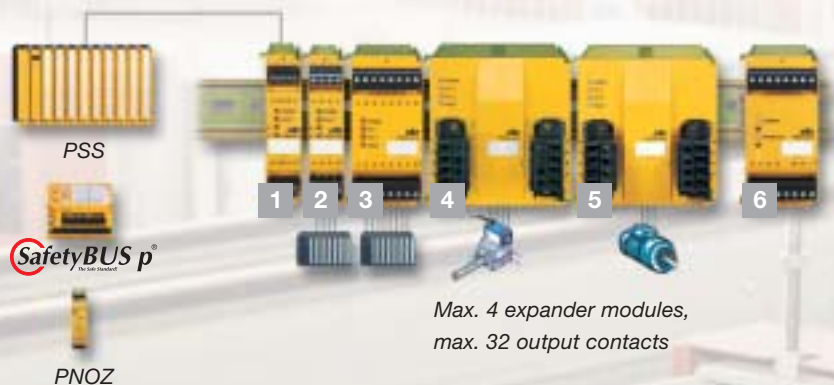

Max. 4 expander modules, max. 32 output contacts

- |                               |                               |
|-------------------------------|-------------------------------|
| 1 Base unit/control module    | 4 Expander module PNOZ po3.2p |
| 2 Expander module PNOZ po3p   | 5 Expander module PNOZ po3.3p |
| 3 Expander module PNOZ po3.1p | 6 Power supply PNOZ pps1p     |

## ► PNOZpower – Technical details

### PNOZpower – Modular safety system – Switching high loads safely



#### PNOZ p1p

Base unit for the PNOZpower modular safety system in accordance with EN 60204-1 (VDE 0113-1), 11/98 and IEC 60204-1, 10/97

Order numbers:

- 773 300 – 24 VDC, plug-in terminals with screw connection
- 783 300 – 24 VDC, plug-in terminals with cage clamp connection

- Category 4, EN 954-1
- Dual-channel operation with or without detection of shorts across contacts
- Monitored or automatic reset can be selected
- Designed to be driven via semiconductor outputs
- 2 semiconductor outputs
- Max. 4 expander modules can be connected
- Supply voltage: 24 VDC
- Output contacts: –
- Switching capability: –
- Dimensions (H x W x D): 94 x 45 x 135 mm



#### PNOZ p1vp

Base unit for the PNOZpower modular safety system in accordance with EN 60204-1 (VDE 0113-1), 11/98 and IEC 60204-1, 10/97

Order numbers:

- 773 950 – 30 s, 24 VDC, plug-in terminals with screw connection
- 773 951 – 300 s, 24 VDC, plug-in terminals with screw connection
- 783 950 – 30 s, 24 VDC, plug-in terminals with cage clamp connection
- 783 951 – 300 s, 24 VDC, plug-in terminals with cage clamp connection

- Category 4, EN 954-1
- Dual-channel operation with or without detection of shorts across contacts
- Monitored or automatic reset can be selected
- Designed to be driven via semiconductor outputs
- 2 semiconductor outputs
- Instantaneous and delayed control of expander modules
- Max. 8 expander modules can be connected: max. 4 that are instantaneous and max. 4 with a delay time
- Delay time can be selected via rotary switch and potentiometer
- Supply voltage: 24 VDC
- Output contacts: –
- Switching capability: –
- Dimensions (H x W x D): 94 x 45 x 135 mm



#### PNOZ pe1p

Control module for the PNOZpower modular safety system in accordance with EN 60204-1 (VDE 0113-1), 11/98 and IEC 60204-1, 10/97

Order numbers:

- 773 900 – 24 VDC, plug-in terminals with screw connection
- 783 900 – 24 VDC, plug-in terminals with cage clamp connection

- Driven via safety contacts or safe semiconductor outputs
- Single-channel operation without detection of shorts across contacts
- Dual-channel operation with or without detection of shorts across contacts
- Output that drives the expander modules is connected to the PNOZpower-Bus
- Max. 4 expander modules can be connected
- Supply voltage: 24 VDC
- Output contacts: –
- Switching capability: –
- Dimensions (H x W x D): 87 x 22.5 x 121 mm





## ► PNOZpower – Technical details

### PNOZpower – Modular safety system – Switching high loads safely



#### **PNOZ po3p**

Expander module for the PNOZpower modular safety system in accordance with EN 60 204-1 (VDE 0113-1), 11/98 and IEC 60 204-1, 10/97

Order numbers:

- 773 634 – Plug-in terminals with screw connection
- 783 634 – Plug-in terminals with cage clamp connection

- Category 4, EN 954-1
- Dual-channel operation with detection of shorts across contacts via the base unit
- LEDs for switch status channel 1/2, supply voltage and fault
- Can only be operated in conjunction with a PNOZpower base unit
- Supply voltage: via PNOZpower-Bus
- Output contacts: 3 safety contacts (N/O); 1 auxiliary contact (N/C)
- Switching capability: AC1: 240 V/4 A; DC1: 24 V/4 A
- Dimensions (H x W x D): 94 x 22.5 x 135 mm



#### **PNOZ po3.1p**

Expander module for the PNOZpower modular safety system in accordance with EN 60 204-1 (VDE 0113-1), 11/98 and IEC 60 204-1, 10/97

Order numbers:

- 773 630 – Plug-in terminals with screw connection
- 783 630 – Plug-in terminals with cage clamp connection

- Category 4, EN 954-1
- Dual-channel operation with detection of shorts across contacts via the base unit
- LEDs for switch status channel 1/2, supply voltage and fault
- Can only be operated in conjunction with a PNOZpower base unit
- Supply voltage: via PNOZpower-Bus
- Output contacts: 8 safety contacts (N/O)
- Switching capability: AC1: 240 V/8 A; DC1: 24 V/8 A
- Dimensions (H x W x D): 94 x 45 x 135 mm



#### **PNOZ po3.2p**

Expander module for the PNOZpower modular safety system in accordance with EN 60 204-1 (VDE 0113-1), 11/98 and IEC 60 204-1, 10/97

Order numbers:

- 773 631 – Plug-in terminals with screw connection
- 783 631 – Plug-in terminals with cage clamp connection

- Category 4, EN 954-1
- Dual-channel operation with detection of shorts across contacts via the base unit
- LEDs for switch status channel 1/2, supply voltage and fault
- Can only be operated in conjunction with a PNOZpower base unit
- Supply voltage: via PNOZpower-Bus
- Output contacts: 4 safety contacts (N/O)
- Switching capability: AC1: 240 V/16 A; 400 V/10 A; DC1: 24 V/16 A
- Dimensions (H x W x D): 94 x 90 x 144 mm

**PNOZpower – Modular safety system – Switching high loads safely**



**PNOZ po3.3p**

Expander module for the PNOZpower modular safety system in accordance with EN 60204-1 (VDE 0113-1), 11/98 and IEC 60204-1, 10/97

Order numbers:

- ▶ 773 632 – 24 VDC, plug-in terminals with screw connection
- ▶ 783 632 – 24 VDC, plug-in terminals with cage clamp connection

- ▶ Category 4, EN 954-1
- ▶ Dual-channel operation with detection of shorts across contacts via the base unit
- ▶ Designed to safely switch loads with utilisation category AC3 (e.g. motor)
- ▶ External start/stop input for non-safety-related switching of a load
- ▶ LEDs for switch status channel 1/2, supply voltage and fault
- ▶ Must be operated in conjunction with a base unit or the control module PNOZ pe1p

- ▶ Supply voltage: via PNOZpower-Bus
- ▶ Output contacts: 3 safety contacts (N/O)
- ▶ Switching capability: AC1: 240 V/16 A; 400 V/10; 500 V/8 A; AC3: 240 V/3 kW; 400 V/5.5 kW; 500 V/4000 W; DC1: 24 V/16 A
- ▶ Dimensions (H x W x D): 94 x 90 x 144 mm



**PNOZ pps1p**

Power supply for the PNOZpower modular safety system

Order numbers:

- ▶ 773 200 – 100 ... 240 VAC/DC, plug-in terminals with screw connection
- ▶ 783 200 – 100 ... 240 VAC/DC, plug-in terminals with cage clamp connection

- ▶ Output voltage 24 VDC
- ▶ Supply voltage : 100 ... 240 VAC/DC
- ▶ Output contacts: –
- ▶ Switching capability: –
- ▶ Dimensions (H x W x D): 94 x 45 x 121 mm



The current status of approvals is available in the corresponding documentation at [www.pilz.com](http://www.pilz.com).



## ► PNOZmulti modular safety system – Many functions

*Low storage costs thanks to multifunctionality in one unit.*

### **Configuration rather than wiring with the PNOZmulti Configurator**

PNOZmulti is a multifunctional, freely configurable and modular safety system.

Unlike the other PNOZ safety relays, with PNOZmulti the safety circuit can be generated easily on the PC using a graphics configuration tool. The motto is “Configuration rather than wiring”. Up to 14 different safety functions can be covered with the base unit.

PNOZmulti is as simple to use as all the safety relays in the PNOZ product range. The standard PNOZ functionalities are extended by an exchangeable memory in the form of a chip card, which can be written and copied as many times as you like. The configuration created on the PC is written to the chip card, which is then inserted into the base unit. The base unit is then attached to the top hat rail and simply wired up – ready.

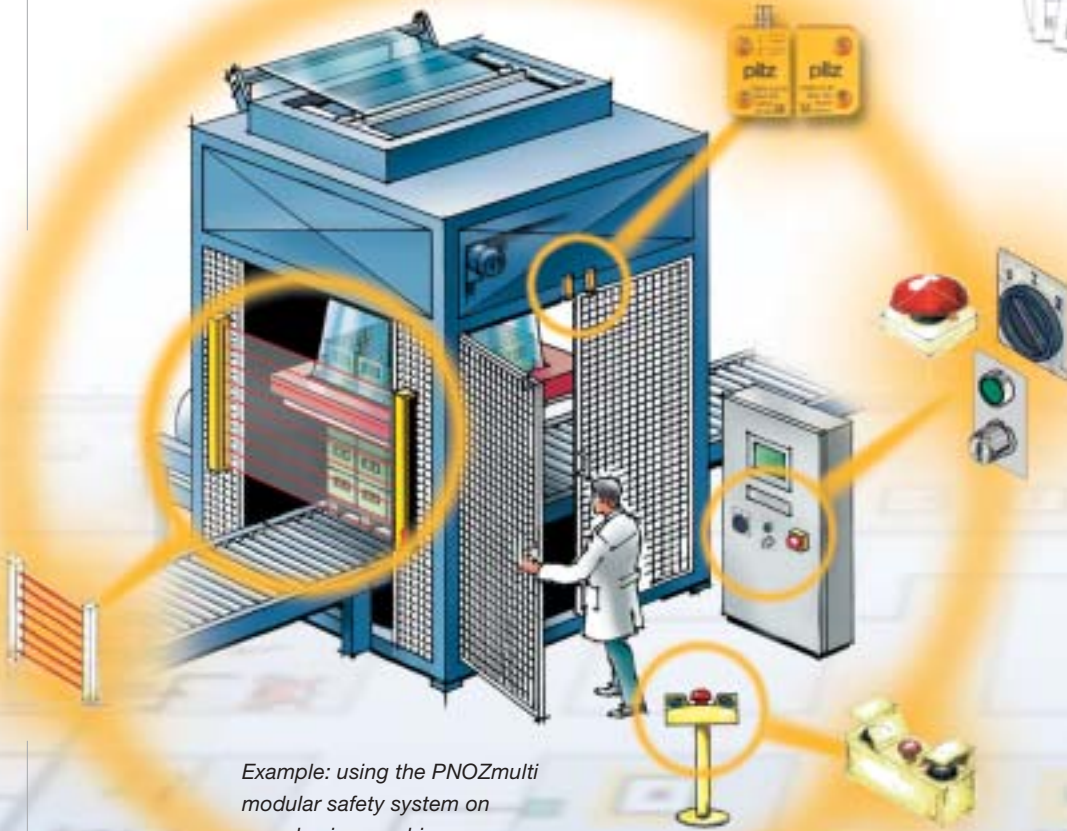

*Example: using the PNOZmulti modular safety system on a packaging machine.*

# ctions – one solution



**1** Configuration is created simply on the PC.

**2** Download to a chip card via a reading device or directly via cable.

**3** Insert the chip into the base unit – the configuration can be implemented.

**4** Print-out can be used as documentation.



3

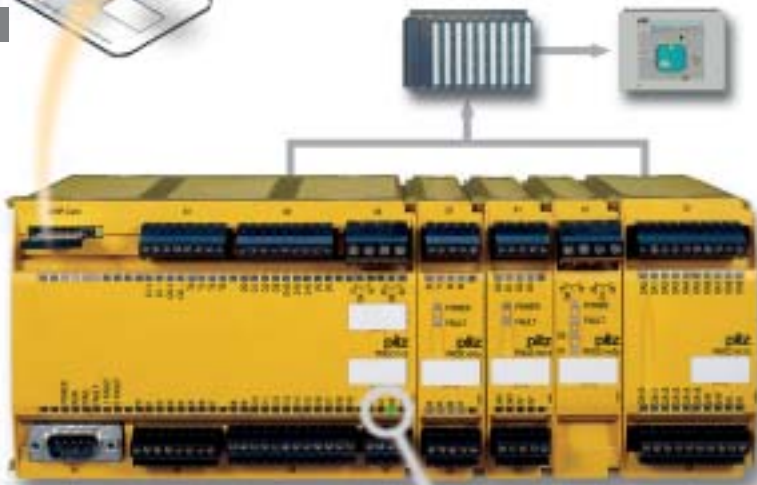

## Diagnostics – Always in the picture

The configuration can be implemented as soon as the chip card has been inserted. No PC is required directly on the machine. High availability is guaranteed thanks to easy-to-use diagnostic options: separate status LEDs are provided on each terminal,

displaying operating and fault statuses. The signal module PNOZ mc1p is available to send signals to a PLC.

## Your benefits at a glance

- ▶ Inputs and outputs are completely configurable using the graphics configuration tool
- ▶ Subsequent configuration changes can be made at any time.
- ▶ No need to draw complex circuit diagrams: simply print out your configuration.
- ▶ Configuration is child's play, no programming knowledge required.
- ▶ Chip card for data transfer is a safe, simple memory medium; easy copy function is of particular interest to series users.
- ▶ Covers the area between 4 and 14 safety functions perfectly, helping to save costs by reducing stockholdings.
- ▶ Simple wiring enables short commissioning times.
- ▶ User-friendly diagnostic options guarantee short downtimes and high plant availability.
- ▶ Economical through adaptation of hardware and lower logistics costs.
- ▶ Scalable through selection of appropriate modules.



Connection to bus systems is in progress.



## ► PNOZmulti – Technical details

### PNOZmulti – Modular safety system

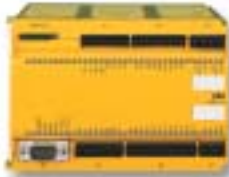

#### PNOZ m1p

Base unit

Application range:

In accordance with EN 954-1, 12/96, up to category 4: E-STOP, two-hand buttons, safety gate, light curtain, scanner, enable switch, PSEN, operating mode selector switch

Order number:

- 773 100 – 24 VDC, no terminals

Accessories:

- 783 100 – 1 set of plug-in cage clamp terminals
- 793 100 – 1 set of plug-in screw terminals
- 779 100 – Tool Kit PNOZmulti
- 779 200 – Chip card set

- 20 freely configurable inputs
- 4 test pulse outputs, 1 auxiliary output
- Configurable using PNOZmulti Configurator via chip card or RS 232 interface
- Exchangeable program memory
- Diagnostic interface
- Max. 8 expander modules can be connected
- Supply voltage ( $U_B$ ): 24 VDC
- Switching capability of semiconductor outputs: 24 VDC/max. 2 A/max. 48 W
- Switching capability of relay outputs: DC1: 24 V/6 A
- Semiconductor outputs: 2 for EN 954-1, 12/96, Cat. 4 or 4 for EN 954-1, 12/96, Cat. 3
- Relay outputs: 1 for EN 954-1, 12/96, Cat. 4 or 2 for EN 954-1, 12/96, Cat. 2
- Dimensions (H x W x D): 94 x 135 x 121 mm



#### PNOZ mi1p

Input module

Application range:

In accordance with EN 954-1, 12/96, up to category 4: E-STOP, two-hand buttons, safety gate, light curtain, scanner, enable switch, PSEN, operating mode selector switch

Order number:

- 773 400 – No terminals

Accessories:

- 783 400 – 1 set of plug-in cage clamp terminals
- 793 400 – 1 set of plug-in screw terminals

- 8 inputs
- Max. 8 input modules can be connected to the base unit
- Connection to base unit via jumper on the back of the unit
- Supply voltage ( $U_B$ ): 24 VDC via base unit
- Switching capability: –
- Semiconductor outputs: –
- Dimensions (H x W x D): 94 x 22.5 x 121 mm



#### PNOZ mo1p

Semiconductor output module

Application range:

In accordance with EN 954-1, 12/96, up to category 4: switching 24 V actuators

Order number:

- 773 500 – No terminals

Accessories:

- 783 400 – 1 set of plug-in cage clamp terminals
- 793 400 – 1 set of plug-in screw terminals

- Max. 6 semiconductor output modules can be connected to the base unit
- Connection to base unit via jumper on the back of the unit
- Supply voltage ( $U_B$ ): 24 VDC via base unit
- Switching capability: 24 VDC/max. 2 A/max. 48 W
- Semiconductor outputs: 2 for EN 954-1, 12/96, Cat. 4 or 4 for EN 954-1, 12/96, Cat. 3
- Dimensions (H x W x D): 94 x 22.5 x 121 mm



The current status of approvals is available in the corresponding documentation at [www.pilz.com](http://www.pilz.com).

### PNOZmulti – Modular safety system



**PNOZ mo2p/PNOZ mo4p**  
Relay output module

Application range:  
In accordance with EN 954-1, 12/96, up to category 4: volt-free switching of actuators

- Order numbers:
- ▶ 773 520 – PNOZ mo2p, no terminals
  - ▶ 773 536 – PNOZ mo4p, no terminals

Accessories:  
▶ On request

- ▶ Max. 6 relay output modules can be connected to the base unit
- ▶ Connection to base unit via jumper on the back of the unit
- ▶ Supply voltage ( $U_B$ ): 24 VDC via base unit
- ▶ Switching capability: DC1: 24 V/6 A
- ▶ Relay outputs:  
PNOZ mo2p: 1 for EN 954-1, 12/96, Cat. 4 or 2 for EN 954-1, 12/96, Cat. 2;  
PNOZ mo4p: 2 for EN 954-1, 12/96, Cat. 4 or 4 for EN 954-1 12/96, Cat. 2
- ▶ Dimensions (H x W x D): 94 x 22.5 x 121 mm



**PNOZ mc1p**  
Signal module

Application range: status message to PLC

- Order number:
- ▶ 773 700 – No terminals

Accessories:

- ▶ 783 700 – 1 set of plug-in cage clamp terminals
- ▶ 793 700 – 1 set of plug-in screw terminals

- ▶ 16 auxiliary outputs using semiconductor technology
- ▶ Max. 8 signal modules can be connected to the base unit
- ▶ Connection to base unit via jumpers on the back of the unit
- ▶ Supply voltage ( $U_B$ ): 24 VDC via base unit
- ▶ Switching capability: –
- ▶ Auxiliary outputs: 16
- ▶ Dimensions (H x W x D): 94 x 45 x 121 mm

### PNOZmulti – Software



**PNOZmulti Configurator**  
Configuration software

- Order number:
- ▶ 773 000...<sup>1)</sup>

- ▶ Runs under Windows® 98/2000 and Windows® NT 4.0
- ▶ Project configuration, configuration generation, documentation, commissioning
- ▶ Data transfer via chip card
- ▶ Graphic configuration of safety circuit

*Get to know the PNOZmulti Configurator without obligation. Request a copy of the free Demo-CD-ROM.*

### PNOZmulti – Accessories



**PNOZmulti Tool Kit**

- Order number:
- ▶ 779 100

Accessories\*:

- ▶ 779 230\* – Chip card reader
- ▶ 779 200\* – Chip card set
- ▶ 310 300\* – Configuration cable
- ▶ 773 000B\* – Documentation folder with single-user licence for PNOZmulti Configurator on CD-ROM
- ▶ 773 050\* – Technical catalogue PNOZmulti

- ▶ Chip card reader to write and save the configuration to a chip card
- ▶ Chip card set consisting of 10 chip cards, including a chip card adapter for rewriting chips removed from the chip cards
- ▶ Configuration cable for reading diagnostic data, configuration download in progress
- ▶ Documentation folder with the PNOZmulti Configurator
- ▶ PNOZmulti technical catalogue: configuration guide with application examples

*The Tool Kit contains the accessories for starting with PNOZmulti.*

\*For use only with subsequent orders.

<sup>1)</sup> When ordering: please state the type of licence you require after the order number (..B for basic licence, ..K for copy licence, ..G for general licence, ..U for update licence), e.g. 773000B.



## ► Safety technology made simple

### **PSEN – The complete solution that's safe and approved**

The PSEN non-contact, magnetic safety switch is used for position monitoring and safety gate monitoring; in conjunction with the following evaluation devices it provides a safe, complete solution from Pilz – with BG approval in accordance with EN 60947-5-3 for applications up to Cat. 4 of EN 954-1. Just one single safety switch is required.

*Safe complete solution for safety gate monitoring up to category 4 in accordance with EN 954-1.*



*PSEN 1.1p-10,  
PSEN 1.1-10*



*Reduced downtimes thanks to plug-in terminals with cage clamp or screw connection.*



### **Plug-in terminals with cage clamp or screw connection**

Units with plug-in terminals offer a great advantage in terms of both economy and safety. The use of plug-in terminals enables short commissioning and service times. With plug-in terminals, additional functionalities can also be implemented in more compact designs. Smaller housing sizes mean more capacity inside the control cabinet. Coded connectors

ensure that units can be exchanged quickly, without problem and without the risk of error; they also increase handling security and therefore reduce downtimes. Cables can also be pre-prepared. The cost-intensive process of labelling wires is no longer necessary, as the cables cannot be inserted incorrectly.

The complete solutions available: PSEN safety switch with

- ▶ PNOZelog\* electronic safety relays
- ▶ PNOZmulti\* modular safety relays
- ▶ PNOZ X and PNOZpower\* safety relays
- ▶ PSS\* programmable safety systems
- ▶ The safe, open bus system SafetyBUS p\*

Depending on the series, PSEN safety switches are available in both a round and a square design, with switching distances of up to 8 mm.

The multiple interfaces PSEN i1 or PSEN ix1 are required if you wish to connect several PSENs to the respective evaluation device in series.

**Your benefits at a glance**

- ▶ Safe from manipulation due to evasion protection in accordance with VDE 0660
- ▶ Insensitive to vibration due to particularly long switching distances
- ▶ Integrates perfectly into the working environment thanks to its small, compact structure
- ▶ Due to the series connection, several safety gates on a plant or machine may be monitored using a single evaluation device
- ▶ Dust-tight and waterproof to the high protection type IP67
- ▶ Insensitive to shock and vibration
- ▶ Long product service life as it is mechanically non-wearing

*\*Please refer to the technical data sheets for information on the exact unit types.*





## ► S-Range electronic monitoring relays – Taking care of your machine

Reliable electronic monitoring and control of plant and machinery is at the heart of the Pilz range of monitoring relays. The new generation of S-Range units in 22.5 mm slimline housing covers up to 70 different functions.

In addition to current, voltage and earth fault monitors, the range also includes relays for true power, phase sequence, and thermistor monitoring. Quick and easy installation, practical terminals, a variety of operator elements as well as luminous displays all help to make commissioning easier and ensure the units are perfectly tailored to the specific application.

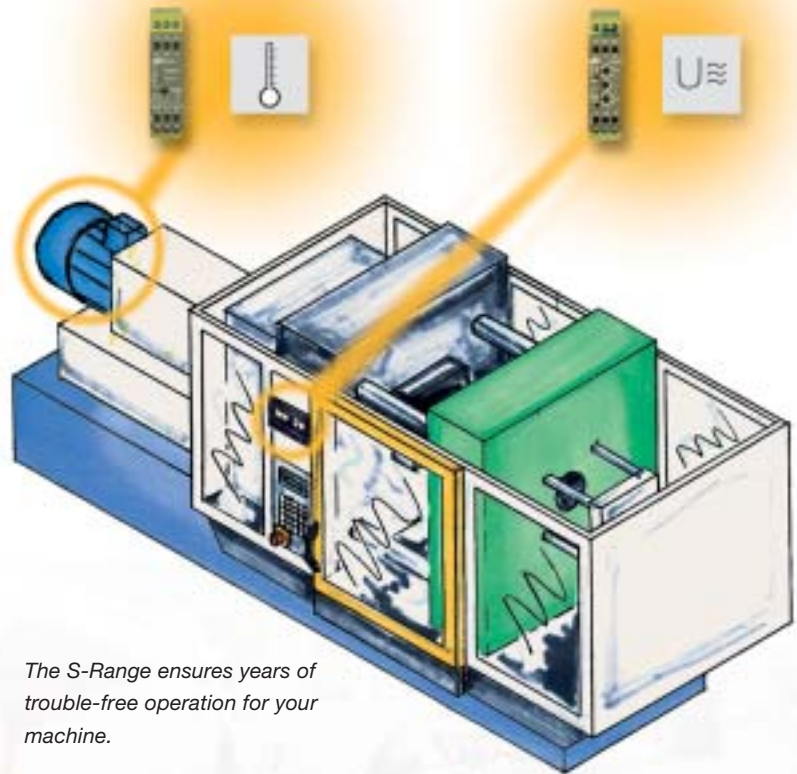

*The S-Range ensures years of trouble-free operation for your machine.*

### S-Range – Technical details



#### S3UM

Three-phase AC voltage monitoring for over-voltage and undervoltage, phase sequence/failure and asymmetry

Order numbers\*:

- ▶ 837 260 – 24 VDC ( $U_B$ ), 230 VAC ( $U_M$ )
- ▶ 837 270 – 24 VDC ( $U_B$ ), 400/440 VAC ( $U_M$ )
- ▶ 837 280 – 24 VDC ( $U_B$ ), 415/460 VAC ( $U_M$ )

- ▶ Monitors supplies with and without a neutral conductor
- ▶ Trip device for undervoltage and overvoltage
- ▶ Evaluates phase sequence
- ▶ Detects asymmetry and phase failure

- ▶ Supply voltage ( $U_B$ ): AC: 120, 230 V; DC: 24 V
- ▶ Output contacts: 1 auxiliary contact (C/O)
- ▶ Measuring voltage ( $U_M$ ): AC: 42, 230, 100/110, 400/440, 415/460, 500/550 V, switchable
- ▶ Dimensions (H x W x D): 87 x 22.5 x 122 mm



#### S1PN

Phase sequence and phase failure monitoring on three-phase supplies

Order numbers\*:

- ▶ 890 200 – 200-240 V
- ▶ 890 210 – 400-500 V
- ▶ 890 220 – 550-690 V

- ▶ Measuring voltage up to 690 VAC
- ▶ Detects asymmetry
- ▶ Monitors phase sequence, phase failure, fuse

- ▶ Supply voltage ( $U_B$ ): AC: 200 ... 240, 400 ... 500, 550 ... 690 V
- ▶ Output contacts: 2 auxiliary contacts (C/O)
- ▶ Dimensions (H x W x D): 87 x 22.5 x 122 mm

# control of every situation

## S-Range – Technical details



### S1IM

Single-phase AC/DC current monitoring for max. current values

Order numbers\*:

- ▶ 828 040 – 110 ... 130 VAC ( $U_B$ ), 15 A ( $I_M$ )
- ▶ 828 050 – 230 ... 240 VAC ( $U_B$ ), 15 A ( $I_M$ )
- ▶ 828 035 – 24 VDC ( $U_B$ ), 15 A ( $I_M$ )

- ▶ 12 measuring ranges from 0.002 to 15 A, selectable
- ▶ Reaction time can be set to up to 10 seconds
- ▶ Operates to normally energised or normally de-energised mode
- ▶ Galvanic isolation between measuring voltage and supply voltage

- ▶ Supply voltage: 24, 42 ... 48, 110 ... 127, 230 ... 240 V; DC: 24 V
- ▶ Output contacts: 1 auxiliary contact (C/O)
- ▶ Dimensions (H x W x D): 87 x 22.5 x 122 mm



### S1EN

Insulation and earth fault monitoring on single and three-phase AC/DC supplies

Order numbers\*:

- ▶ 884 100 – 24 ... 240 VAC/DC ( $U_B$ ), 50 k $\Omega$
- ▶ 884 110 – 24 ... 240 VAC/DC ( $U_B$ ), 200 k $\Omega$

- ▶ For DC and AC supplies
- ▶ Normally energised mode
- ▶ Fault latching or automatic reset
- ▶ Normal/test mode

- ▶ Supply voltage: AC/DC: 24 ... 240 V
- ▶ Output contacts: 1 auxiliary contact (C/O)
- ▶ Nominal mains voltage (monitored supply):  
50 k $\Omega$  version: AC/DC: 0 ... 240 V  
200 k $\Omega$  version: AC/DC: 0 ... 400 V
- ▶ Dimensions (H x W x D): 87 x 22.5 x 122 mm



### S1WP

Monitors and converts true power, single/three-phase AC/DC supplies, relay and analogue output, overload and underload monitoring

Order numbers\*:

- ▶ 890 010 – 9 A ( $I_M$ ), 24 VDC ( $U_B$ ), 0 ... 240 VAC/DC
- ▶ 890 020 – 9 A ( $I_M$ ), 24 VDC ( $U_B$ ), 0 ... 415 VAC/DC
- ▶ 890 030 – 9 A ( $I_M$ ), 24 VDC ( $U_B$ ), 0 ... 550 VAC/DC

- ▶ 9 different measuring ranges
- ▶ Large voltage measuring range
- ▶ Analogue output can be switched for current and voltage
- ▶ Relay output for monitoring overload and underload
- ▶ Suitable for use with frequency-controlled motors

- ▶ Supply voltage: DC: 24 V, AC/DC: 230 V
- ▶ Output contacts: 1 auxiliary contact (C/O)
- ▶ Measuring voltage: 3 AC/1 AC/DC: 0 ... 120, 0 ... 240, 0 ... 415, 0 ... 550 V
- ▶ Dimensions (H x W x D): 87 x 22.5 x 122 mm



### S1MS

Thermistor monitoring for PTC temperature sensors, protecting motors from overheating

Order numbers\*:

- ▶ 839 775 – 24 VAC/DC ( $U_B$ )
- ▶ 839 760 – 230 VAC ( $U_B$ )
- ▶ 839 770 – 400 VAC ( $U_B$ )

- ▶ For DC and AC supplies
- ▶ Normally energised mode
- ▶ Automatic reset

- ▶ Supply voltage: AC: 48, 110, 120, 230, 400 V; AC/DC: 24 V
- ▶ Output contacts: 2 auxiliary contacts (C/O)
- ▶ Dimensions (H x W x D): 87 x 22.5 x 122 mm

\*Other versions on request.

Order number features:  $U_B$  = supply voltage;  $U_M$  = measuring voltage;  $I_M$  = measuring current;  $R_{on}$  = response value.

The current status of approvals is available in the corresponding documentation at [www.pilz.com](http://www.pilz.com).





## ► Safety technology – Further information



*First-hand  
knowledge of  
safety.*

### Seminars and training

Pilz offers training courses and seminars worldwide in the national language. Further information on what we can offer is available on the Internet at [www.pilz.com](http://www.pilz.com), under Service/ Training and Education. You can also request our training documentation.

### Internet

Current information on our PNOZ product range is available at [www.pilz.com](http://www.pilz.com). Many documents are available to download as pdf files under Service/Download:

- ▶ Data sheets
- ▶ Operating manuals
- ▶ Technical catalogues
- ▶ Promotional literature and much more



*[www.pilz.com](http://www.pilz.com)  
– just click on it!*

### CD-ROM Pilz Guide – Company and Products

The latest version of the “Pilz Guide - Company and Products” provides comprehensive information on our company and product range under the motto: “Safe automation”. Application examples and data sheets, plus the ability to dial up the Internet directly, make product selection easier.



### Pilz Service Applications CD with EPLAN macros

For fast, simple design and documentation of your circuits, Pilz has developed a practical tool with special Pilz product macros under EPLAN. The macros are available in German and English.

Order number:  
▶ 301 996

or order online in our Pilz Shop  
at [www.pilz.com](http://www.pilz.com)



### Your benefits at a glance

Safety relays in the PNOZ product range offer:

- ▶ The security and innovative power of one of the leading brands in automation technology
- ▶ The appropriate safety solution for each application
- ▶ Fewer downtimes, high plant availability and therefore cost savings
- ▶ Optimum cost/performance ratio
- ▶ Units with plug-in terminals, ensuring faster commissioning
- ▶ Highest level of safety with the least space requirement
- ▶ Simple wiring, fast commissioning and user-friendly diagnostic options
- ▶ A solid partner offering a comprehensive range of services, such as safety advice, training and much more
- ▶ Certified safety, because our products comply with international standards and regulations and have been tested and approved worldwide
- ▶ Quality guarantee, because we are certified to DIN ISO 9001
- ▶ The PNOZ product ranges are continually expanded, so they are geared for the future

**Request for information and consultation**

**Please copy this section and return the completed form to one of the Fax numbers overleaf.**

I would like a no-obligation consultation on your products and services. Please call me.

**Please send me information on:**

- 1** Your company
- 2** Your services, e.g. project management, risk analysis, safety concepts, etc.
- 3** Your training courses and seminars

**Please send me further information on the following product groups**

- 4** S-Range control and monitoring technology
- 5** PIT ES command and signal
- 6** PSEN sensor technology
- 7** Compact safety relays PNOZclassic, PNOZ X, PNOZelog
- 8** Modular safety relays PNOZmulti, PNOZpower, PNOZplus
- 9** PSS programmable safety systems
- 10** SafetyBUS p safe bus systems
- 11** Operating and monitoring PX, PXT, PMI

\_\_\_\_\_  
 Company

Title  Mr  Mrs/Ms

\_\_\_\_\_  
 Surname

\_\_\_\_\_  
 First name

\_\_\_\_\_  
 Department

\_\_\_\_\_  
 Street

\_\_\_\_\_  
 Post code/Town

\_\_\_\_\_  
 State/County

\_\_\_\_\_  
 Country

\_\_\_\_\_  
 Telephone

\_\_\_\_\_  
 Telefax

\_\_\_\_\_  
 E-Mail

\_\_\_\_\_  
 Industry

2-4-2-2-008-04/03



**Always  
 up-to-date:  
 www.pilz.com**

**A**

Pilz Ges.m.b.H.  
 Modecerstraße 14  
 1030 Wien  
 Austria  
 Telephone: 01 7986263-0  
 Telefax: 01 7986264  
 E-Mail: pilz@pilz.at

**AUS**

Pilz Australia  
 Industrial Automation LP.  
 9/475 Blackburn Road  
 Mt. Waverley, Melbourne VIC 3149  
 Australia  
 Telephone: 03 95446300  
 Telefax: 03 95446311  
 E-Mail: safety@pilz.com.au

**B L**

Pilz Belgium  
 Bijenstraat 4  
 9051 Gent (Sint-Denijs-Westrem)  
 Belgium  
 Telephone: 09 3217570  
 Telefax: 09 3217571  
 E-Mail: info@pilz.be

**BR**

Pilz do Brasil Sistemas Eletrônicos  
 Industriais Ltda.  
 Rua Ártico, 123 - Jd. do Mar  
 09726-300  
 São Bernardo do Campo - SP  
 Brazil  
 Telephone: 11 4337-1241  
 Telefax: 11 4337-1242  
 E-Mail: pilz@pilzbr.com.br

**CH**

Pilz Industrieelektronik GmbH  
 Gewerbepark Hintermättli  
 Postfach 6  
 5506 Mägenwil  
 Switzerland  
 Telephone: 062 88979-30  
 Telefax: 062 88979-40  
 E-Mail: pilz@pilz.ch

**D**

Pilz GmbH & Co.  
 Sichere Automation  
 Felix-Wankel-Straße 2  
 73760 Ostfildern  
 Germany  
 Telephone: 0711 3409-0  
 Telefax: 0711 3409-133  
 E-Mail: pilz.gmbh@pilz.de

**DK**

Pilz Skandinavien K/S  
 Ellegaardvej 25 L  
 6400 Sønderborg  
 Denmark  
 Telephone: 74436332  
 Telefax: 74436342  
 E-Mail: pilz@pilz.dk

**E**

Pilz Industrieelektronik S.L.  
 Camí Ral, 130  
 Polígono Industrial Palou Nord  
 08400 Granollers  
 Spain  
 Telephone: 938497433  
 Telefax: 938497544  
 E-Mail: pilz@pilz.es

**F**

Pilz France Electronic  
 1, rue Jacob Mayer  
 BP 12  
 67037 Strasbourg Cedex  
 France  
 Telephone: 03 88104000  
 Telefax: 03 88108000  
 E-Mail: siege@pilz-france.fr

**FIN**

Pilz Skandinavien K/S  
 Pakilantie 61  
 00660 Helsinki  
 Finland  
 Telephone: 09 27093700  
 Telefax: 09 27093709  
 E-Mail: pilz.fi@pilz.dk

**GB**

Pilz Automation Technology  
 Willow House, Medicott Close  
 Oakley Hay Business Park  
 Corby  
 Northants NN18 9NF  
 United Kingdom  
 Telephone: 01536 460766  
 Telefax: 01536 460866  
 E-Mail: sales@pilz.co.uk

**I**

Pilz Italia Srl  
 Via Meda 2/A  
 22060 Novedrate (CO)  
 Italy  
 Telephone: 031 789511  
 Telefax: 031 789555  
 E-Mail: info@pilz.it

**IRL**

Pilz Ireland Industrial Automation  
 Cork Business and Technology Park  
 Model Farm Road  
 Cork  
 Ireland  
 Telephone: 021 4346535  
 Telefax: 021 4804994  
 E-Mail: sales@pilz.ie

**J**

Pilz Japan Co., Ltd.  
 Fujika Building 5F  
 2-5-9 Shin-Yokohama  
 Kohoku-ku  
 Yokohama 222-0033  
 Japan  
 Telephone: 045 471-2281  
 Telefax: 045 471-2283  
 E-Mail: pilz@pilz.co.jp

**MEX**

Pilz de Mexico, S. de R.L. de C.V.  
 Circuito Pintores # 170  
 Cd. Satelite  
 C.P. 53100  
 Naucalpan de Juarez, Edo. de Mexico  
 Mexico  
 Telephone: 55 5572 1300  
 Telefax: 55 5572 4194  
 E-Mail: info@mx.pilz.com

**NL**

Pilz Nederland  
 Postbus 186  
 4130 ED Vianen  
 Netherlands  
 Telephone: 0347 320477  
 Telefax: 0347 320485  
 E-Mail: info@pilz.nl

**NZ**

Pilz New Zealand  
 3 Kohanga Road  
 Managere Bridge  
 Auckland  
 New Zealand  
 Telephone: 09-6345350  
 Telefax: 09-6345350  
 E-Mail: t.catterson@pilz.co.nz

**P**

Pilz Industrieelektronik S.L.  
 R. Eng Duarte Pacheco, 120  
 4 Andar Sala 21  
 4470-174 Maia  
 Portugal  
 Telephone: 229407594  
 Telefax: 229407595  
 E-Mail: pilz@pilz.es

**PRC**

Pilz China Representative Office  
 Rm. 302  
 No. 88 Chang Shu Road  
 Shanghai 200040  
 China  
 Telephone: 021 62493031  
 Telefax: 021 62493036  
 E-Mail: sales@pilz.com.cn

**ROK**

Pilz Korea Office  
 402 Samsung Midas Officetel  
 775-1, Janghang-Dong,  
 Ilsan-Gu, Koyang-Si  
 Kyungki-Do 411-837  
 Korea  
 Telephone: 031 8159541  
 Telefax: 031 8159542  
 E-Mail: info@pilzkorea.co.kr

**SE**

Pilz Skandinavien K/S  
 Energigatan 10 B  
 43437 Kungsbacka  
 Sweden  
 Telephone: 0300 13990  
 Telefax: 0300 30740  
 E-Mail: pilz.se@pilz.dk

**TR**

Pilz Elektronik Güvenlik Ürünleri  
 ve Hizmetleri Tic. Ltd. Şti.  
 Tan İş Merkezi  
 Kükürtlü Caddesi No: 67  
 C-Blok Daire: 1  
 16080 Bursa  
 Turkey  
 Telephone: 0224 2360180  
 Telefax: 0224 2360184  
 E-Mail: pilz.tr@pilz.de

**USA**

Pilz Automation Safety L.P.  
 7150 Commerce Boulevard  
 Canton  
 Michigan 48187  
 USA  
 Telephone: 734 354-0272  
 Telefax: 734 354-3355  
 E-Mail: info@pilzusa.com

**...**

In many countries we are  
 represented by sales partners.

Please refer to our Homepage  
 for further details or contact our  
 headquarters.

**WWW**

[www.pilz.com](http://www.pilz.com)



Pilz GmbH & Co.  
 Sichere Automation  
 Felix-Wankel-Straße 2  
 73760 Ostfildern, Germany  
 Telephone: +49 711 3409-0  
 Telefax: +49 711 3409-133  
 E-Mail: pilz.gmbh@pilz.de

**pilz**  
 more than automation  
 safe automation